

DOCUMENT RESUME

ED 304 183

JC 890 103

TITLE Master Plan for Data Processing Services, 1988-1993. Report.

INSTITUTION Connecticut Regional Community Colleges, Hartford. Board of Trustees.

PUB DATE Jul 88

NOTE 62p.; Cover title: "Data Processing Long Range Plan, 1988-1993."

PUB TYPE Viewpoints (120)

EDRS PRICE MF01/PC03 Plus Postage.

DESCRIPTORS Community Colleges; *Computer Oriented Programs; *Computer Uses in Education; Database Management Systems; *Data Processing; Educational Planning; *Long Range Planning; Management Information Systems; Master Plans; Microcomputers; Needs Assessment; Personnel Needs; Program Improvement; *Statewide Planning; Telecommunications; Two Year Colleges

IDENTIFIERS *Connecticut

ABSTRACT

Developed in accordance with a legislative mandate, this master plan for Connecticut's regional community colleges provides baseline data on the current status of data processing; identifies issues, trends, and constraints; and sets forth specific plans for computing activities and services within the community college system. Introductory sections examine the mandate and mission of the colleges, constraints on the mission and objectives of their data processing program, and statewide priorities and objectives. The next section provides baseline information on hardware and telecommunications configurations, data processing personnel, use of microcomputers, and nine existing computer-based administrative systems. Next, the plan considers staffing needs, fiscal year 1989 priorities for a personnel and budget information system, systemwide integration among current administrative systems, microcomputer local area networks, and a UNIX operating system environment for computer science students. Finally, plans for upgrading equipment and telecommunications are presented. The bulk of the report consists of appendixes which offer information on the computer capabilities of the system and individual colleges, a list of data processing staff positions at each college, and detailed cost projections. (AJL)

 * Reproductions supplied by EDRS are the best that can be made *
 * from the original document. *

ED304183

"PERMISSION TO REPRODUCE THIS
MATERIAL HAS BEEN GRANTED BY

R. Williams

TO THE EDUCATIONAL RESOURCES
INFORMATION CENTER (ERIC)."

U.S. DEPARTMENT OF EDUCATION
Office of Educational Research and Improvement
EDUCATIONAL RESOURCES INFORMATION
CENTER (ERIC)

This document has been reproduced as
received from the person or organization
originating it.

Minor changes have been made to improve
reproduction quality.

• Points of view or opinions stated in this docu-
ment do not necessarily represent official
OERI position or policy

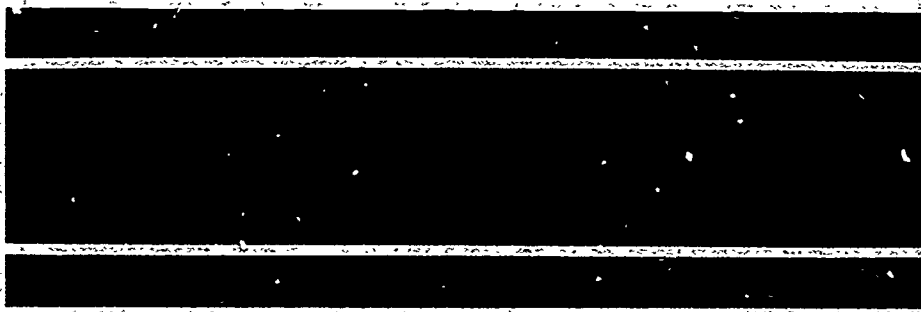

DATA PROCESSING LONG RANGE PLAN 1988-1993



61 Woodland Street • Hartford, CT • 06105

**BOARD OF TRUSTEES
CONNECTICUT REGIONAL COMMUNITY COLLEGES
MASTER PLAN FOR DATA PROCESSING SERVICES 1988-1993**

Please direct comments or questions to:

Kenneth Elterich, Ph.D.
Director of Research and Information Systems
Board of Trustees
Connecticut Regional Community Colleges

KE
7/88

**BOARD OF TRUSTEES
CONNECTICUT COMMUNITY COLLEGES**

MASTER PLAN FOR DATA PROCESSING SERVICES 1988-1993

The College Master Plan for Data Processing Services has been developed in accordance with Public Act 83-175 which modified Section 3-116a of the Connecticut General Statutes. This act requires each agency to institute a long-range data processing plan with the assistance and approval of the Department of Administrative Services. The master plan provides current data processing baseline information, identifies issues, trends and constraints, and sets forth specific future plans regarding computing activities and services within the community college system.

STATUTORY MANDATE AND MISSION

The mandate and mission of Connecticut Community Colleges are delineated by the Connecticut General Assembly in Public Act 75-100, and were incorporated into Connecticut's General Statutes (Sec. 10-382).

The community college system consists of twelve two year institutions whose mission is to identify and address the educational needs of the individuals and regions that they serve by providing a broad range of occupational, transfer and general programs and a wide variety of services. Because they are primarily oriented to their service regions, community colleges are unique with regard to certain individual efforts, emphases and priorities. Planning, developing and administering the colleges is the responsibility of a Board of Trustees.

Each community college provides a variety of courses of study which are two years or less in duration and which may lead to associate degrees, certificates or simply to the short-term acquisition of specific job skills. Currently programs offered in data processing are designed to prepare both full- and part-time students for entry and advancement in local data processing job markets. The colleges also provide hands-on activity for the general student population via computer assisted instruction, word processing and computer literacy.

In addition to offering degree-related programs, options, and certificates, the community colleges provide continuing education, upgrading, and retraining for numerous professions. Each year the colleges deliver hundreds of courses, workshops, and conferences which often are customized for a specific employer and held at convenient times at the company. The community college mission encourages the colleges to respond to the needs of diverse student and community groups, including professionals and large and small businesses in the

colleges' service regions. These needs are met by providing instruction in computerization of various business activities. For example, the establishment of microcomputer local area networks provides the education and training services that keep pace with technological change.

Efforts to increase the administrative processing capabilities of the local campuses and the Central Office are essential elements of the system-wide data processing mission. Of top priority are data processing applications that improve the system's ability to meet its financial and personnel management internal needs and in response to outside agency requirements. In addition, the Executive Director established a System Task Force to review the community colleges' administrative data processing systems and to recommend the implementation process for a comprehensive, integrated information system.

Issues and Constraints Impacting the Regional Community College's Data Processing Mission and Objectives.

Reduced federal resources, rising costs for system development and limited technical support are but some of the challenges for the community colleges to overcome. Expected implementation and expansion of data processing services will vary by college and will depend on the amount of available resources.

1. A lack of adequate technical staffing is the primary constraint within the community college system.

2. There is an urgent need to fully automate the fiscal and budget preparation functions and to fully integrate this information into a total management information system. However, several statewide systems being implemented at other agencies have impacted the automation of these functions as these new mandated systems have required considerable staff effort.

3. There is a continual need to upgrade equipment to keep pace with rapidly changing technology and to meet additional demands for computing resources.

DATA PROCESSING MISSION

In support of its mission, the community college system strives to provide computer resources and support services for the academic activities and the administrative departments within each of the colleges. This includes satisfying the academic data processing course work requirements, meeting the demand for word processing and computer literacy, and supporting the administrative data processing needs of the system in general.

Strategic Directions

1. Enhance the community colleges ability to deliver automated services to meet their instructional and administrative requirements.
2. Maintain the necessary computer equipment at the System Data Center to satisfactorily handle the centralized computing needs of the colleges and the Board of Trustees.
3. Support the colleges innovative use of computing resources, including the utilization of personal computers and local area networking as a means of distributed data processing.
4. Provide maintenance and/or replacement support for the equipment base at the colleges. Many terminals, printers, and data communication's devices are near or exceeding their projected life.
5. Continue the long-term development and implementation of common integrated administrative applications.
6. Continue to coordinate and manage the system's telecommunication network and implement a comprehensive strategy for meeting future network requirements.
7. Provide continued support for the colleges' library automation activities.
8. Implement a system-wide office automation project that would provide office automation equipment in the administrative offices of each campus. This project would provide uniformity for the basic functions of word processing, document filing and transfer, and electronic mail.
9. Work toward the establishment of an information service center to assist the colleges in developing and promoting data processing services and programs. Secure additional programming personnel and train the local college staffs to support the new administrative on-line systems.
10. Provide sufficient hardware and support services for the colleges' academic programs, including the data processing curricula, computer literacy, and CAI activities. Continue to investigate and apply new data processing technology to the instructional programs of the community colleges.

Software Development Objectives

1. Implement a comprehensive, integrated system for admissions, applicant tracking, financial aid, registration and cashing functions, including tuition and fee collections, accountability and tallying course enrollments.
2. Integration of the above student information system with the general ledger, budgeting and human resource system.
3. Redesign and program the RCC Personnel system (i.e., PBIS). Develop interface mechanisms so that it can provide the necessary data elements required by the State Payroll, Personnel and Retirement Systems, and interface with MaRKOS to satisfy the course and instructor requirements of the DHE statewide management information system.

CURRENT DATA PROCESSING BASELINE

Hardware and telecommunications configurations. The System Data Center is located on the ground floor of Greater Hartford Community College in Hartford provides academic and administrative computer resources for the community colleges. The Center's computer hardware consists of two Digital Equipment Corporation systems - a VAX 8810 with 124 megabytes of main memory and a VAX 8650 with 76 megabytes of main memory - that currently support approximately 350-375 user terminals.

The VAX computers are interconnected in a cluster arrangement that make it possible to share data files and peripheral equipment such as disk and tape drives and printers. Both VAX CPUs are connected to the IBM 3084 located at the University of Connecticut Computer Center in Storrs using a batch bisynchronous links and IBM's HASP multileaving protocol. The VAXes are also linked through DECnet to the Department of Higher Education, the State University System, and to the Department of Administrative Service's Data Center. The State Data Center can also be directly accessed using a 3270 emulation board on the Center's communication switch.

The off-campus sites are connected via leased telephone lines through multiplexors and modems to the Data Center's communication's switch (i.e., Gandalf Starmaster) from which campus users can make connection to any of the Center's computers. Appendix A presents a table containing the number of communication lines, the line speeds, and the number of multiplexor ports from each campus. The colleges can also access CMS at UConn utilizing their existing network and terminals through an extended communication's link between the two Data Centers (see Appendix B). In addition, Asnuntuck Community College in Enfield and has a local DEC PDP 11/70 computers that support it's academic requirements.

Planning and implementation of standardized hardware and software has been a policy within the community college system. The standardization has occurred with the administrative processing as all of the colleges use common software systems run at the System Data Center. Administrative capacity at each location is satisfactory but review and planning procedures are in place to insure that sufficient equipment will be in place for future requirements.

Academic equipment, particularly microcomputers, pose support problems as a large number of microcomputers currently exist on the campuses. Initially, specifications were drawn for microcomputer purchases by the college making the purchase and the State Purchasing Bureau went out to bid. This has resulted, in some cases, of colleges having different brands of microcomputers in their student laboratories. However, it is recognized that continued support must be provided in the form of installation, maintenance, mainframe compatibility, consulting, and instruction in order for microcomputers to be of the greatest use to the college community. Thus, to minimize instructional disruptions due to changing technology, the Board of Trustees has initiated policy to limit the number of brands of microcomputers in the community colleges.

Regional Community College's Data Processing Personnel

The community colleges' data processing personnel are dispersed among the System Data Center and the 12 college locations. The Center's staff is responsible for the operation of the Data Center, maintenance of current application systems, new development work, installing and maintaining communication's hardware, and training and assisting users with the hardware/software systems.

The campus Data Processing Coordinator provides administrative support at the local level and acts as a liaison with the System Data Center staff. They are responsible for local ad hoc report generation, supervising the operation of the college's data processing activities, and serving as a resource to local administrative and academic users. In some cases, the coordinators provide support to the academic divisions by coordinating lab activities. Asnuntuck and Manchester have staff in their Data Centers for computer system management activities.

The coordinators are an essential link between the Data Center and local data processing activities. They assist the local college personnel in defining their requirements and work with the Data Center when appropriate to meet those requirements. Technical involvement by the coordinators in development projects is crucial if the current backlog of applications is to be addressed in a reasonable timeframe.

Use of Microcomputers. Microcomputers are an essential aspect of the colleges' equipment inventory and are used in microcomputer labs designed to foster computer literacy in a wide variety of curricular areas. Instruction is provided through hands-on laboratory experiences for students in data processing and computer programming courses, and, increasingly, to students for word processing applications. Additionally, instructors in accounting, mathematics, art and many other disciplines have devised computer applications in their fields and are using them to supplement classroom activities.

Administrative and instructional word processing activities have played a major role in the community colleges' data processing expansion. Because of a shortage of clerical support staff, the colleges' administrative and faculty offices depend upon automated support through various stand-alone word processing equipment and/or software available on the system computers. Administrative offices have found it extremely useful to utilize integrated software packages on microcomputers for many tasks rather than using single function word processors.

In addition to these activities, the colleges participate in regional library informational networks that provide community college students with access to the holdings of all participating libraries. The goal is to have all the libraries participate in the On-line Cataloging Library Center (OCLC) for nationwide access.

Current administrative line systems:

(1) MaRKOS - an on-line student data management system that provides the college management personnel with a planning and information tool. It includes student biographical and course information, grading, transcripts, an internal report writer and query language (i.e., MaRKEY), admissions, add-drop activities, and some financial aid reporting.

Date of Production:	1982
Processing Location:	System Data Center
Central Processor Used:	DEC VAX Cluster
Annual Operating Cost:	N/A
Assessment of Operation:	Satisfactory

2. SAAAS - State Agency Appropriation Accounting System. This systems allows the business offices at each campus to maintain accounting ledgers required by the Comptroller. It is capable of generating many types of detailed and summary appropriation and expenditure reports both locally at the campus level and for the community college system. A Purchase Order Encumbrance module will be released during FY89.

Date of Production:	1979
Processing Location:	System Data Center
Central Processor Used:	DEC VAX Cluster
Annual Operating Cost:	\$4200

Assessment of Operation: Needs Revision

(3) PBIS - Personnel and Budgeting Information System. Currently used for position control and budgeting purposes. On-line query is possible at the agency level, data-entry and report writing is limited to central administrative staff.

Date of Production:	1983
Processing Location:	System Data Center
Central Processor Used:	DEC VAX Cluster
Annual Operating Cost:	N/A

Assessment of Operation: Needs revision.

(4) Full-time and Part-time Employee Time and Attendance System. This system maintains daily employee attendance records and provides year-to-date detail (i.e., types of days taken) reporting.

Date of Production:	1980
Processing Location:	System Data Center
Central Processor Used:	DEC VAX Cluster
Annual Operating Cost:	N/A

Assessment of Operation: Needs Revision

(5) Physical and Supplies Inventory Systems. This system is used by several of the colleges to maintain equipment inventory records required by the Comptroller. A new version of the inventory system will incorporate useful life information and will enable data entry via mark sense equipment.

Date of Production:	1980
Processing Location:	System Data Center
Central Processor Used:	DEC VAX Cluster
Annual Operating Cost:	N/A

Assessment of Operation: Needs revision

(6) Capital Project Tracking System. This system contains data relating to the status of community college capital projects administered by the Bureau of Public Works. It includes information on funding costs, design, and construction status. Standardized reports are generated.

Date of Production: 1982
Processing Location: Dept. of Higher Ed.
Central Processor Used: DEC VAX 11/750
Annual Operating Cost: N/A

Assessment of Operation: Satisfactory

(7) B-66 Appropriation Analysis. An automated spreadsheet system that provides the calculation and printing of the Comptroller's monthly B-66 Appropriation Analysis forms. Data entry and reconciliation is done at the campus level with system consolidation completed at the Central Office.

Date of Production: 1985
Processing Location: System Data Center
Central Processor Used: DEC VAX Cluster
Annual Operating Cost: N/A

Assessment of Operation: Satisfactory

(8) Course File System. This system provides course file data twice a year to the Department of Higher Education from the MARKOS student information system. Information is provided on enrollment counts, field of study, course location and instructors. The data file is used by Central Staff to generate various reports including the instructional formulas for budgeting.

Date of Production: 1983
Processing Location: System Data Center
Central Processor Used: DEC VAX Cluster
Annual Operating Cost: N/A

Assessment of Operation: Needs revision.

(9) Student File System. This system provides student file data twice a year to the Department of Education. Information is provided on each student concerning various biographical items, major, transfer status, financial aid and academic background. The student files from each campus are automatically extracted and transmitted to the DHE via the MARKOS student information system.

Date of Production: 1983
Processing Location: System Data Center
Central Processor Used: DEC VAX Cluster
Annual Operating Cost: N/A

Assessment of Operation: Satisfactory

In addition to the above systems, several administrative software packages have been acquired for our academic and non-technical administrative users. These packages support ad hoc report requests for management related information. These include, Datatrieve, Digicalc, Word-11, Graphics-11, IBGraph, SAS and SMARTSTAR.

PLANNED DATA PROCESSING PROJECTS

Staffing. The immediate and future application program development requirements are considerable. The technical staff of the Board (i.e., 8 FTE) must address internal priorities generated from the colleges' needs, those of the Central Office management staff, and external agency requirements.

Additional staff support is desperately needed in the system development area. Additional analyst/programming support is essential if the Data Center is to continue to support the community colleges' software development efforts. Such important projects as the student accounts receivable and financial aid module to the MARKOS student information system and the integration of the Personnel system to the MARKOS course file for DHE data reporting have not been addressed because the Data Center staff have been assigned to more immediate development and maintenance projects.

The colleges also require technical support and expertise in the academic computing area. The colleges' personal computer inventories continue to expand and computing instruction is being provided in all areas of the curriculum. However, there is a continued need to review and evaluate our current course offerings so as to keep pace with changing market needs. As new technologies are implemented within the system (e.g., local area microcomputer networking) there will be a demand for coordination, support and leadership from the System Data Center.

Additional user support is also needed. Over the past several years the numbers of users and applications have increased dramatically. The addition of an RCC Personnel/Payroll interface to the state mandated system will further increase the Center's responsibilities in providing direct user assistance and technical expertise to new campus users in the Business and Personnel offices. Past experience indicates that the most common cause of new electronic data processing program failure is the lack of, or poor, documentation and training. Thus, clear, concise documentation and appropriate user training is essential if the colleges' faculty and staff are going to utilize the Data Center's applications and services. User support personnel would provide general information and training to the Data Center's users regarding system concepts, new compiler languages and system software.

Over the years the community college system has recognized the importance of having local data processing staff to define and coordinate their campus data processing requirements and to provide a link with the Data Center staff. At Quinebaug Valley in Danielson the

college's registrar and other administrative staff have supported these activities. With the addition of new on-line systems, new microcomputer laboratories, and other new technology the job has grown in complexity and full-time support is required. Thus the FY90 budget requests a Director of Data Processing to coordinate Quinebaug's growing academic program and administrative requirements.

System Activities. During FY89, priority will be given to implementing the PBIS personnel system. The objective is to move toward a single data entry requirement for all personnel and payroll functions with automated interfaces with the state systems. ADABAS, a data base management system, has been purchased in order to better manage and maintain data in a nonredundant structure. ADABAS contains a screen generator, and report and query language capabilities.

Several system-wide councils have indicated that the need for integration among the current administrative systems. This requirement has been recognized by the Data Center staff and it feels that moving toward a comprehensive, integrated information system is an essential element of our system-wide data processing approach. Thus, the Executive Director initiated a System Task Force to review the colleges' administrative data processing systems and to develop uniform information detailing requirements and specifications. Initially, the Committee has been charged with the following:

- . Define long-term administrative DP needs for colleges., internal and external.
- . Prepare one combined specifications document.
- . Develop a Request for Proposal document.
- . Select and implement systems.

Several functional areas were defined by the Committee for possible discussion and review, these included:

Accounting	Counselling
Personnel/Payroll	Cashing/Tuition & Fees
Purchasing/Inventory	Development/Alumni
Records	Facilities Usage
Admissions	Marketing
Financial Aid	Continuing Ed/Community Services
Library Administration	Business Services
Budgeting	Institutional Research
General Admin. Usage/Communication	

Specific planned system development activities include:

(1) Modification to Personnel and Budget Information System (PBIS) - redesign and program using a data base management system. The new system will include separate position and employee files and integration with other State/Community College systems.

Processing Location:	System Data Center
Central Processor Used:	DEC VAX Cluster
Development Cost:	NA

Implementation schedule:	FY89
--------------------------	------

(2) Microcomputer Local Area Networks - microcomputer local area network are being installed at each campus purchased through High Technology Bond Funds. Continued funding has been approved through a second High Technology grant for FY89.

Initially the LAN will be configured to accommodate six microcomputers and a single network server, however, the colleges' would like to increase the LANs in size so that an entire class (i.e., 25 workstations) could be serviced. The LANs will enhance the quality of high technology instructional programs within the community colleges and will provide a working environment found in business and industry. The colleges' institutional services will also be enhanced by improving and expanding the capabilities of existing computer laboratories used by students, faculty, and businesses. The equipment configuration permits a student to use a microcomputer as a stand-alone unit, or as a component of a local area network, or as a terminal to the System Data Center's computers.

Processing Location:	Agency Equipment
Central Processor Used:	Microcomputer based
Development Cost:	\$327,500

Implementation Schedule:	FY88-FY89
--------------------------	-----------

(3) MicroVAX II - UNIX System - there's a critical need to offer a UNIX operating system environment to the colleges' computer science students. The Data Center plans to purchase a computer system running the UNIX operating system that would be accessed through the existing telecommunication system in the Data Center. Students could then communicate on an interactive basis with the VAX/VMS, VAX/UNIX and an IBM system (UConn) utilizing our current terminal network. This arrangement would provide a unique learning environment for the community college student.

Processing Location:	System Data Center
Central Processor Used:	DEC MicroVAX II - UNIX
Development Cost:	\$50,000

Implementation Schedule:	FY89
--------------------------	------

System Activities:

In FY89 the Data Center will expand and upgrade the Data Center's communications switch to accommodate additional users and computer ports as well as the implementation of an Ethernet network in the Data Center and to the Board office on the third floor and to Greater Hartford's student laboratory. Increased processing capability and memory requirements will also be required on the VAX systems as new administrative systems are implemented.

Over the next few years several equipment/telecommunications upgrades have been planned:

(1) The community college's current telecommunication's network is based on antiquated technology that inhibits local expansion and flexibility. In order to accommodate additional users and increase the flexibility of operating and monitoring the telecommunication's system an upgrade of the network, both in the Data Center and at the campus level, is planned during FY89-90

(2) Replace older microcomputers, terminals, printers, etc. with new equipment, at the rate of fifty units per year between fiscal year FY88 and FY92. And, provide additional administrative and academic workstations to those colleges requiring expansion.

(3) Implement system-wide word processing capability that would present an opportunity to tie office automation with the other shared systems and to provide standardization for the basic functions of word processing, document filing and transfer, graphics, spreadsheet functions, and electronic mail. This project is planned for over a multi-year period beginning in FY88.

(4) Acquire sufficient numbers of microcomputers for the campus' computer laboratories. The objective is to purchase up-to-date equipment and software that best meet the needs of the colleges and provide their students with recognized job market skills.

(5) Library Automation - the Community Colleges will continue to participate in inter-institutional cooperative activity and encourage inter-library exchange as a means of enhancing the services offered to the college community. To enhance the community colleges' links to regional and national data bases, the Board of Trustees has initiated a system-wide library automation cataloging project based with the On-line Cataloging Library Center (OCLC). The objectives of this project are to develop a data base for the community colleges, provide each library access to OCLC for ongoing cataloging and conversion, provide access to a national data base for inter-library loans, and to train library staffs in the use of OCLC.

The project is currently being implemented with workstations purchased through a CONNLINET grant and funds reallocated for the Board of Trustees operating budget to support institutional membership, start-up charges, and initial on-line computer cataloging

charges with the national data base service center.

The timeframe for the retrospective cataloging has been planned to take from five to seven years based on resources currently available. The funding for the ongoing costs of current cataloging will continue to be necessary in the current service budget. Additional funds were requested in the FY88 budget for part-time data entry personnel and related expenses for on-line computer cataloging for the computer project. This funding, unfortunately, was not included in the Governor's Budget Recommendation which will result in an extended timetable for full implementation of this initiative.

College Expansion Requirements. Additional terminals, line printers and other equipment required at the colleges to meet their own administrative needs and to fully implement the proposed management information system will be purchased during FY89-FY92. The colleges will replace current equipment with terminals incorporating graphics, word processing, etc., and additional printers, including laser printers, are required in various offices or labs on campus.

SUMMARY FORMS.

The following pages contain institutional and system summary forms:

1. Multi-year Summary - Administrative + Academic Plans
2. Five Year Planned Computer Project Costs - Administrative Plan
3. Multi-year Summary - Administrative Plan
4. Five Year Planned Computer Project Costs - Academic Plan
5. Multi-year Summary - Academic Plan
6. System Expenditure Summary - Administrative + Academic Plans
7. RCC System Expenditure Summary - Administrative Plan
8. Institutional Expenditure Summaries - Administrative Plan
9. RCC System Expenditure Summary - Academic Plan
10. Institutional Expenditure Summaries - Academic Plan
11. Listing of DP Staff in Connecticut Community Colleges

The institutional and system expenditure and multi-year summary forms have been developed using the following guidelines:

1. DP staff have been identified using the Regional Community College Personnel/Budgeting Information System with corresponding annual salaries. Salaries have been extended using 5%.
2. Equipment and Other Expense expended dollars were extracted from institutional SAAAS reports and equipment lists. Figures include institutional expenses for library automation.
3. Multi-year summaries include baseline data extended using the following percentages (5% for P.S., 5% for operating expense, and 5% for equipment dollars), plus any budget add-ons for that year.

APPENDIX A

CONNECTICUT REGIONAL COMMUNITY COLLEGES REMOTE TERMINAL NETWORK TO SYSTEM DATA CENTER

<u>LOC. NAME</u>	<u>TOWN</u>	<u>LINE</u>	<u>MODEM</u>	<u>CURRENT TERMINALS</u>	<u>INCREASES IN # OF TERMINALS</u>
Data Center	Hartford	- 15	locally connected	terminals	
Bd. of Trustees (3rd. floor)		- 24	"	"	12
G. Hartford C.C.		- 32	"	"	6
Asnuntuck	Enfield	1	9600 bps	16	
Manchester	Manchester	1	4800 bps	12	20
		2	2400 bps	16	
		3	4800 bps	printer	
Tunxi	Farmington	1	9600 bps	16	
		2	4800 bps	12	12
Northwestern	Winsted	1	4800 bps	16	
		2	2400 bps	4	8
Mattatuck	Waterbury	1	4800 bps	12	4
		2	9600 bps	16	
Norwalk	Norwalk	1	2400 bps	12	8
		2	4800 bps	12	
Housatonic	Bridgeport	1	9600 bps	16	
		2	4800 bps	16	
South Central	New Haven	1	2400 bps	16	
		2	9600 bps	16	
Middlesex	Middletown	1	4800 bps	16	4
		2	4800 bps	12	
Mohegan	Norwich	1	2400 bps	12	16
Quinebaug V.	Danielson	1	4800 bps	16	
TOTAL				335	90

Note, all terminals run at 2400 baud.

REGIONAL COMMUNITY COLLEGES' TELECOMMUNICATIONS NETWORK

RCC DATA CENTER

UCONN COMPUTER CENTER

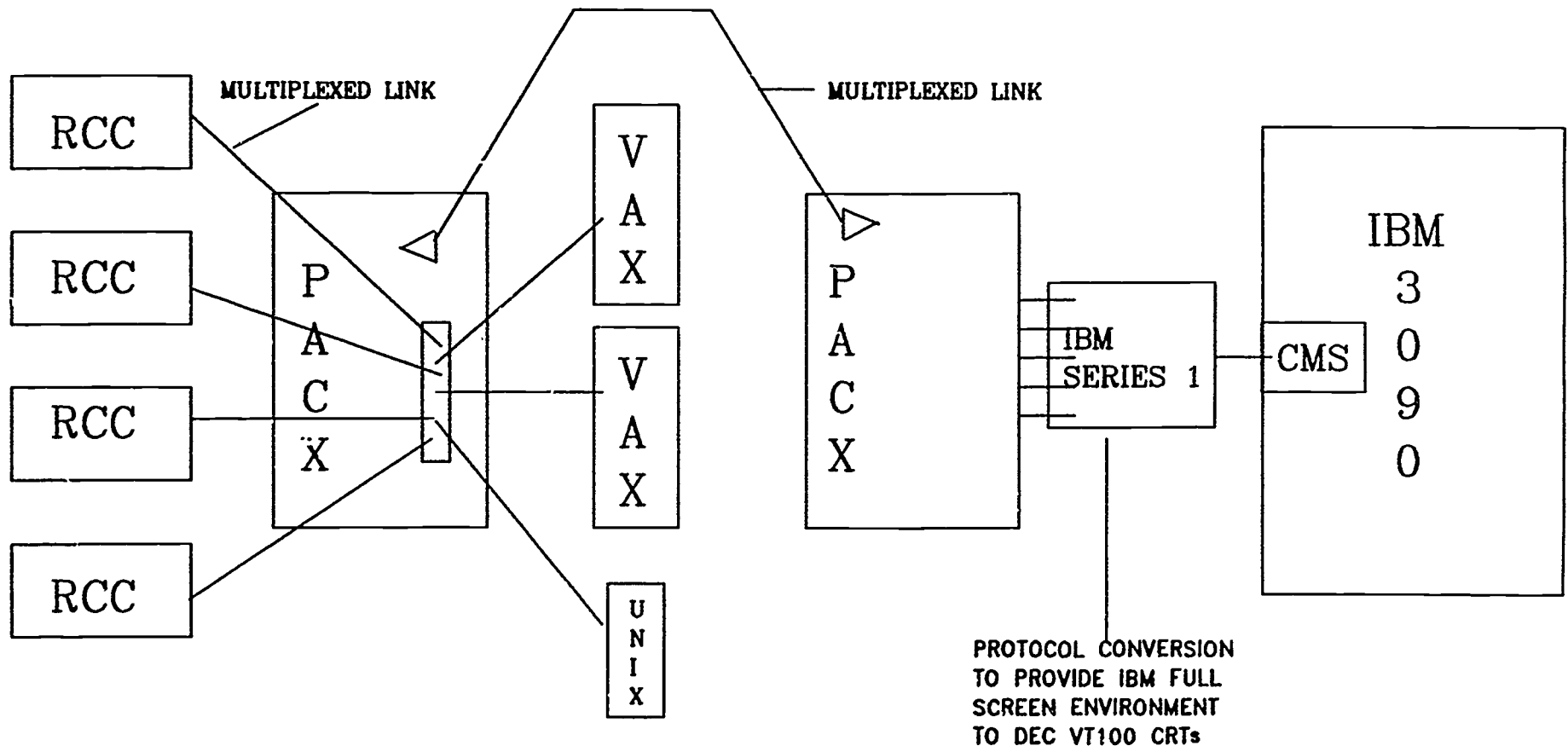

LISTING OF DATA PROCESSING STAFF
CONNECTICUT COMMUNITY COLLEGES

Board of Trustees

- (1) Director of Research & Information Systems
- (1) Director of the System Data Center
- (1) Assistant Director for Applications Development
- (1) Director of User Services and Telecommunications
- (1) Senior Programmer Analyst
- (3) Programmers
- (1) Computer Operator
- (1) P-T Computer Operator

Asnuntuck Community College

- (1) Data Systems Manager & DP Coordinator
- (1) Computer Lab Coordinator

Greater Hartford Community College

- (1) Director of Data Processing
- (1) Computer Operator
- (1) Data Entry Clerk
- (1) Lab Coordinators
- (2) P-T Faculty Lab Coordinators

Housatonic Community College

- (1) DP Coordinator
- (1) Computer Operator
- (1) Lab Assistant

Manchester Community College

- (1) Director of Data Processing
- (1) Assistant Director of Data Processing
- (1) Assistant Director for Academic Computing
- (1) Programmer
- (1) Data Entry Clerk
- (1) P-T Operations Assistant
- (1) Lab Assistant

Mattatuck Community College

- (1) DP Coordinator
- (1) Computer Operator
- (1) Computer Services Aide

Middlesex Community College

- (1) DP Coordinator
- (1) DP Assistant
- (1) P-T Data Entry
- (2) P-T Lab Assistant

Mohegan Community College

- (1) DP Coordinator
- (1) Computer Operator
- (1) Lab Assistant

Northwestern Connecticut Community College

- (1) Director, Computer Services
- (1) Data Entry Operator
- (1) Technical Lab Assistant

Norwalk Community College

- (1) Director of the Data Center, Research & Records
- (1) Assistant Director of the Data Center & Research
- (2) Academic Lab Assistant

South Central Community College

- (1) Director of Data Information Systems
- (1) Computer Operator
- (1) Data Entry Clerk

Tunxis Community College

- (1) Director of Data Processing.
- (1) Coordinator of Data Processing

REGIONAL COMMUNITY COLLEGES
MULTI-YEAR SUMMARY

	87/88 ACTUAL	88/89 BUDGETED YEAR	FY90 YEAR 1	YEAR 2	YEAR 3	YEAR 4	YEAR 5
<u>SUMMARY</u>							
Personal Services							
Positions	49.00	49.99	52.00	54.00	57.00	60.00	63.00
Cost	\$1,159,816	\$1,322,807	\$1,472,114	\$1,604,420	\$1,744,641	\$1,891,873	\$2,046,466
Other Expense							
Con't	\$581,177	\$642,048	\$673,794	\$977,483	\$1,221,358	\$1,432,426	\$1,664,247
Nonrecurring	\$0	\$0	\$25,000	\$25,000	\$0	\$0	\$0
Equipment	\$1,015,774	\$1,012,702	\$1,653,486	\$1,396,160	\$2,135,969	\$2,532,767	\$3,199,405
OTHER FUNDS	\$345,537	\$277,032	\$98,856	\$103,799	\$108,989	\$114,438	\$120,160
PROJECT TOTAL	<u>\$3,102,304</u>	<u>\$3,254,589</u>	<u>\$3,323,250</u>	<u>\$4,106,862</u>	<u>\$5,210,956</u>	<u>\$5,971,504</u>	<u>\$7,030,079</u>

REGIONAL COMMUNITY COLLEGES
ADMINISTRATIVE PLAN
FIVE YEAR PLANNED COMPUTER PROJECT COSTS

88/89 BUDGETED YEAR	FY90 YEAR 1	YEAR 2	YEAR 3	YEAR 4	YEAR 5
1. IMPLEMENT INTEGRATED MANAGEMENT INFO SYSTEM					
Personal Services					
Positions					
Cost	\$0	\$32,700 ¹	\$0	\$0	\$0
Other Expense					
Con't - MAINT.	\$75,000	\$125,000	\$125,000	\$35,000	\$35,000
Nonrecurring	\$0	\$25,000	\$25,000	\$0	\$0
Equipment	\$0	\$75,000	\$0	\$0	\$0
PROJECT TOTAL	\$75,000	\$257,700	\$150,000	\$35,000	\$35,000
TELECOMMUNICATIONS PROJECT					
Personal Services					
Positions					
Cost	\$0	\$0	\$0	\$0	\$0
Other Expense					
Con't - MAINT.	\$50,000	\$65,000	\$65,000	\$110,000	\$65,000
Nonrecurring	\$0	\$0	\$0	\$0	\$0
Equipment	\$50,000	\$67,000	\$130,000	\$130,000	\$130,000
PROJECT TOTAL	\$100,000	\$132,000	\$195,000	\$370,000	\$195,000
SUMMARY OF PROJECTS					
Personal Services					
Positions	0	1	0	0	0
Cost	0	32,700	0	0	0
Other Expense					
Con't	125,000	190,000	190,000	145,000	100,000
Nonrecurring	0	25,000	25,000	0	0
Equipment	50,000	142,000	130,000	260,000	130,000
TOTAL PROJECTS COST	\$175,000	\$389,700	\$345,000	\$405,000	\$230,000

REGIONAL COMMUNITY COLLEGES
SYSTEM DATA PROCESSING SUMMARY
MULTI-YEAR ADMINISTRATIVE SUMMARY

	87/88 ACTUAL	88/89 BUDGETED YEAR	FY90 YEAR 1	YEAR 2	YEAR 3	YEAR 4	YEAR 5
SUMMARY							
Personal Services							
Positions	35.00	35.00	36.00	36.00	36.00	36.00	36.00
Cost	\$1,010,171	\$1,069,630	\$1,145,414	\$1,202,685	\$1,262,819	\$1,325,960	\$1,392,258
Other Expense							
Con't	\$298,342	\$329,034	\$345,129	\$552,385	\$725,005	\$861,255	\$1,004,318
Nonrecurring	\$0	\$0	\$25,000	\$25,000	\$0	\$0	\$0
Equipment	\$571,822	\$538,048	\$577,459	\$736,332	\$1,033,149	\$1,214,896	\$1,405,546
OTHER FUNDS	\$31,385	\$14,000	\$14,000	\$14,700	\$15,435	\$16,207	\$17,017
PROJECT TOTAL	\$1,911,720	\$1,942,667	\$2,107,002	\$2,531,102	\$3,036,407	\$3,418,228	\$3,819,139

REGIONAL COMMUNITY COLLEGES
ACADEMIC PLAN
FIVE YEAR PLANNED COMPUTER PROJECT COSTS

	88/89 BUDGETED YEAR	FY90 YEAR 1	YEAR 2	YEAR 3	YEAR 4	YEAR 5
1. MICROCOMPUTERS & LOCAL AREA NETWORKS						
Personal Services Positions	0	0	1	3	3	3
Cost	\$0	\$0	\$27,000	\$60,000	\$60,000	\$60,000
Other Expense						
Con't	\$120,000	\$65,000	\$65,000	\$25,000	\$25,000	\$25,000
Nonrecurring	\$0	\$0	\$0	\$0	\$0	\$0
Equipment	\$285,300	\$160,000	\$160,000	\$160,000	\$160,000	\$160,000
PROJECT TOTAL	\$485,300	\$225,000	\$252,000	\$245,000	\$245,000	\$245,000
2. UPGRADE ACADEMIC COMPUTERS						
Personal Services Positions	0	0	1	0	0	0
Cost	\$0	\$0	\$31,700	\$0	\$0	\$0
Other Expense						
Con't - MAINT.	\$15,000	\$15,000	\$15,000	\$25,000	\$25,000	\$35,000
Nonrecurring	\$0	\$0	\$0	\$0	\$0	\$0
Equipment	\$75,000	\$0	\$0	\$250,000	\$0	\$250,000
PROJECT TOTAL	\$90,000	\$15,000	\$46,700	\$275,000	\$25,000	\$285,000
SUMMARY OF PROJECTS						
Personal Services Positions	0	0	2	3	3	5
Cost	\$0	\$0	\$58,700	\$60,000	\$60,000	\$60,000
Other Expense						
Con't	135,000	80,000	80,000	50,000	50,000	0,000
Nonrecurring	\$0	\$0	\$0	\$0	\$0	\$0
Equipment	360,300	160,000	160,000	410,000	160,000	410,000
TOTAL PROJECTS COST	\$495,300	\$240,000	\$298,700	\$520,000	\$270,000	\$530,000

• HIGH TECHNOLOGY BOND FUNDS

REGIONAL COMMUNITY COLLEGES
SYSTEM DATA PROCESSING SUMMARY
MULTI-YEAR ACADEMIC SUMMARY

	87/88 ACTUAL	88/89 BUDGETED YEAR	FY90 YEAR 1	YEAR 2	YEAR 3	YEAR 4	YEAR 5
SUMMARY							
Personal Services							
Positions	14.00	14.00	16.00	18.00	21.00	24.00	27.00
Cost	\$149,645	\$262,127	\$326,700	\$401,735	\$481,822	\$565,913	\$654,288
Other Expense	\$282,835	\$313,014	\$328,665	\$425,098	\$496,353	\$571,171	\$659,729
Con't	\$0	\$0	\$0	\$0	\$0	\$0	\$0
Nonrecurring							
Equipment	\$443,952	\$473,751	\$476,027	\$659,828	\$1,102,820	\$1,317,961	\$1,793,859
OTHER FUNDS	\$314,152	\$263,432	\$84,856	\$89,099	\$93,554	\$98,231	\$103,143
PROJECT TOTAL	<u>\$1,190,584</u>	<u>\$1,311,927</u>	<u>\$1,216,248</u>	<u>\$1,575,760</u>	<u>\$2,174,548</u>	<u>\$2,553,276</u>	<u>\$3,210,940</u>

REGIONAL COMMUNITY COLLEGES
SYSTEM EXPENDITURES

	87/88 CURRENT YEAR	88/89 BUDGETED YEAR	PLAN YEAR 1		(89/90) TOTAL
			EXPEND. BASE	REQUIRED NEW FUNDS	
GENERAL FUND					
Personal Services Positions	49	49	49	3	52
Cost	\$1,259,816	\$1,322,807	\$1,388,947	\$83,166	\$1,472,113
Other Expense Con't	\$127,808	\$168,679	\$198,113	\$0	\$198,113
Nonrecurring Equipment	\$276,593	\$39,889	\$61,309	\$0	\$61,309
SUBTOTAL	\$1,664,217	\$1,551,375	\$1,648,369	\$83,166	\$1,731,535
TUITION FUND					
Personal Services Positions	0	0	0	0	0
Cost	\$0	\$0	\$0	\$0	\$0
Other Expense Con't	\$453,369	\$453,369	\$475,681	\$0	\$475,681
Nonrecurring Equipment	\$739,181	\$972,813	\$992,177	\$0	\$992,177
SUBTOTAL	\$1,192,550	\$1,426,182	\$1,467,858	\$0	\$1,467,858
EXTENSION FUND	\$26,399	\$31,000	\$32,000	\$0	\$32,000
AUXILIARY SERVICES	\$42,492	\$9,169	\$7,528	\$0	\$7,528
FEDERAL FUNDS	\$46,341	\$61,506	\$37,656	\$0	\$37,656
OTHER	\$230,305	\$175,357	\$32,672	\$0	\$32,672
TOTAL	<u>\$3,202,304</u>	<u>\$3,254,589</u>	<u>\$3,226,083</u>	<u>\$83,166</u>	<u>\$3,309,249</u>
TOTAL POSITIONS	49	49	49	3	52

REGIONAL COMMUNITY COLLEGES
ADMINISTRATIVE DP PLAN

INSTITUTIONAL EXPENDITURE SUMMARY

	87/88	88/89	PLAN YEAR 1		(89/90)
	CURRENT YEAR	BUDGETED YEAR	EXPEND. BASE	REQUIRED NEW FUNDS	TOTAL
GENERAL FUND					
Personal Services					
Positions	35	35	35	1	36
Cost	\$1,010,171	\$1,060,680	\$1,113,714	\$31,700	\$1,145,414
Other Expense					
Con't	\$85,972	\$116,664	\$122,497	\$0	\$122,497
Nonrecurring	\$0	\$0	\$0	\$0	\$0
Equipment	\$227,549	\$33,889	\$55,309	\$0	\$55,309
SUBTOTAL	\$1,323,692	\$1,211,233	\$1,291,520	\$31,700	\$1,323,220
TUITION FUND					
Personal Services					
Positions	0	0	0	0	0
Cost	\$0	\$0	\$0	\$0	\$0
Other Expense					
Con't	\$212,370	\$212,370	\$222,632	\$0	\$222,632
Nonrecurring	\$0	\$0	\$0	\$0	\$0
Equipment	\$344,273	\$505,059	\$522,150	\$0	\$522,150
SUBTOTAL	\$556,643	\$717,429	\$744,782	\$0	\$744,782
EXTENSION FUND	\$1,835	\$0	\$11,000	\$0	\$11,000
AUXILIARY SERVICES	\$25,858	\$0	\$0	\$0	\$0
FEDERAL FUNDS	\$0	\$0	\$0	\$0	\$0
OTHER	\$3,694	\$14,000	\$14,000	\$0	\$14,000
TOTAL	<u>\$1,911,720</u>	<u>\$1,942,662</u>	<u>\$2,061,302</u>	<u>\$31,700</u>	<u>\$2,093,002</u>
TOTAL POSITIONS	35	35	35	1	36

BOARD OF TRUSTEES
ADMINISTRATIVE DP PLAN

INSTITUTIONAL EXPENDITURE SUMMARY

	87/88	88/89	PLAN YEAR 1		(89/90)
	CURRENT YEAR	BUDGETED YEAR	EXPEND. BASE	REQUIRED NEW FUNDS	TOTAL
<u>GENERAL FUND</u>					
Personal Services					
Positions	10	10	10	1	11
Cost	\$345,078	\$362,332	\$380,448	\$31,700	\$412,148
Other Expense					
Con't	\$37,000	\$38,000	\$39,900	\$0	\$39,900
Nonrecurring	\$0	\$0	\$0	\$0	\$0
Equipment	\$95,576	\$0	\$0	\$0	\$0
SUBTOTAL	\$477,654	\$400,332	\$420,348	\$31,700	\$452,048
<u>TUITION FUND</u>					
Personal Services					
Positions	0	0	0	0	0
Cost	\$0	\$0	\$0	\$0	\$0
Other Expense					
Con't	\$45,000	\$45,000	\$47,250	\$0	\$47,250
Nonrecurring	\$0	\$0	\$0	\$0	\$0
Equipment	\$194,968	\$405,000	\$405,000	\$0	\$405,000
SUBTOTAL	\$239,968	\$450,000	\$452,250	\$0	\$452,250
EXTENSION FUND	\$0	\$0	\$0	\$0	\$0
AUXILIARY SERVICES	\$0	\$0	\$0	\$0	\$0
FEDERAL FUNDS	\$0	\$0	\$0	\$0	\$0
OTHER	\$0	\$0	\$0	\$0	\$0
TOTAL	<u>\$717,622</u>	<u>\$850,332</u>	<u>\$872,598</u>	<u>\$31,700</u>	<u>\$904,298</u>
TOTAL POSITIONS	10	10	10	1	11

ASNUNTUCK C.G.
ADMINISTRATIVE DP PLAN

INSTITUTIONAL EXPENDITURE SUMMARY

	87/88 CURRENT YEAR	88/89 BUDGETED YEAR	PLAN YEAR 1 (89/90)		TOTAL
			EXPEND. BASE	REQUIRED NEW FUNDS	
GENERAL FUND					
Personal Services					
Positions	0	0	0	0	0
Cost	\$0	\$0	\$0	\$0	\$0
Other Expense					
Con't	\$0	\$4,500	\$4,725	\$0	\$4,725
Nonrecurring	\$0	\$0	\$0	\$0	\$0
Equipment	\$11,323	\$11,889	\$12,484	\$0	\$12,484
SUBTOTAL	\$11,323	\$16,389	\$17,209	\$0	\$17,209
TUITION FUND					
Personal Services					
Positions	0	0	0	0	0
Cost	\$0	\$0	\$0	\$0	\$0
Other Expense					
Con't	\$2,266	\$2,266	\$2,379	\$0	\$2,379
Nonrecurring	\$0	\$0	\$0	\$0	\$0
Equipment	\$0	\$0	\$0	\$0	\$0
SUBTOTAL	\$2,266	\$2,266	\$2,379	\$0	\$2,379
EXTENSION FUND	\$0	\$0	\$0	\$0	\$0
AUXILIARY SERVICES	\$0	\$0	\$0	\$0	\$0
FEDERAL FUNDS	\$0	\$0	\$0	\$0	\$0
OTHER	\$0	\$0	\$0	\$0	\$0
TOTAL	\$13,589	\$18,655	\$19,588	\$0	\$19,588
TOTAL POSITIONS	0	0	0	0	0

GREATER HARTFORD C.C.
ADMINISTRATIVE DP PLAN

INSTITUTIONAL EXPENDITURE SUMMARY

	87/88 CURRENT YEAR	88/89 BUDGETED YEAR	PLAN YEAR 1 (89/90)		
			EXPEND. BASE	REQUIRED NEW FUNDS	TOTAL
GENERAL FUND					
Personal Services					
Positions	3	3	3	0	3
Cost	\$76,674	\$80,508	\$84,533	\$0	\$84,533
Other Expense					
Con't	\$0	\$4,500	\$4,725	\$0	\$4,725
Nonrecurring	\$0	\$0	\$0	\$0	\$0
Equipment	\$7,509	\$8,000	\$8,000	\$0	\$8,000
SUBTOTAL	\$84,183	\$93,008	\$97,258	\$0	\$97,258
TUITION FUND					
Personal Services					
Positions	0	0	0	0	0
Cost	\$0	\$0	\$0	\$0	\$0
Other Expense					
Con't	\$11,136	\$11,136	\$11,693	\$0	\$11,693
Nonrecurring	\$0	\$0	\$0	\$0	\$0
Equipment	\$9,789	\$10,000	\$10,000	\$0	\$10,000
SUBTOTAL	\$20,925	\$21,136	\$21,693	\$0	\$21,693
EXTENSION FUND	\$0	\$0	\$0	\$0	\$0
AUXILIARY SERVICES	\$0	\$0	\$0	\$0	\$0
FEDERAL FUNDS	\$0	\$0	\$0	\$0	\$0
OTHER	\$3,694	\$0	\$0	\$0	\$0
TOTAL	\$108,802	\$114,144	\$118,951	\$0	\$118,951
TOTAL POSITIONS	3	3	3	0	3

HOUSATONIC C.C.
ADMINISTRATIVE DP PLAN

INSTITUTIONAL EXPENDITURE SUMMARY

	87/88 CURRENT YEAR	88/89 BUDGETED YEAR	PLAN YEAR 1 (89/90)		
			EXPEND. BASE	REQUIRED NEW FUNDS	TOTAL
<u>GENERAL FUND</u>					
Personal Services					
Positions	2	2	2	0	2
Cost	\$50,983	\$53,532	\$56,209	\$0	\$56,209
Other Expense					
Con't	\$926	\$4,500	\$4,725	\$0	\$4,725
Nonrecurring	\$0	\$0	\$0	\$0	\$0
Equipment	\$932	\$0	\$0	\$0	\$0
SUBTOTAL	\$52,841	\$58,032	\$60,934	\$0	\$60,934
<u>TUITION FUND</u>					
Personal Services					
Positions	0	0	0	0	0
Cost	\$0	\$0	\$0	\$0	\$0
Other Expense					
Con't	\$17,227	\$17,227	\$18,088	\$0	\$18,088
Nonrecurring	\$0	\$0	\$0	\$0	\$0
Equipment	\$8,929	\$10,000	\$12,000	\$0	\$12,000
SUBTOTAL	\$26,156	\$27,227	\$30,088	\$0	\$30,088
EXTENSION FUND	\$0	\$0	\$0	\$0	\$0
AUXILIARY SERVICES	\$0	\$0	\$0	\$0	\$0
FEDERAL FUNDS	\$0	\$0	\$0	\$0	\$0
OTHER	\$0	\$0	\$0	\$0	\$0
TOTAL	\$78,997	\$85,259	\$91,022	\$0	\$91,022
TOTAL POSITIONS	2	2	2	0	2

MANCHESTER C.C.
ADMINISTRATIVE DP PLAN

INSTITUTIONAL EXPENDITURE SUMMARY

	87/88 CURRENT YEAR	88/89 BUDGETED YEAR	PLAN YEAR 1 (89/90)		
			EXPEND. BASE	REQUIRED NEW FUNDS	TOTAL
GENERAL FUND					
Personal Services					
Positions	5	5	5	0	5
Cost	\$124,923	\$131,169	\$137,728	\$0	\$137,728
Other Expense					
Con't	\$3,697	\$4,500	\$4,725	\$0	\$4,725
Nonrecurring	\$0	\$0	\$0	\$0	\$0
Equipment	\$15,807	\$7,500	\$7,875	\$0	\$7,875
SUBTOTAL	\$144,427	\$143,169	\$150,328	\$0	\$150,328
TUITION FUND					
Personal Services					
Positions	0	0	0	0	0
Cost	\$0	\$0	\$0	\$0	\$0
Other Expense					
Con't	\$37,581	\$37,581	\$39,460	\$0	\$39,460
Nonrecurring	\$0	\$0	\$0	\$0	\$0
Equipment	\$89,646	\$23,000	\$24,150	\$0	\$24,150
SUBTOTAL	\$127,227	\$60,581	\$63,610	\$0	\$63,610
EXTENSION FUND	\$0	\$0	\$11,000	\$0	\$11,000
AUXILIARY SERVICES	\$0	\$0	\$0	\$0	\$0
FEDERAL FUNDS	\$0	\$0	\$0	\$0	\$0
OTHER	\$0	\$0	\$0	\$0	\$0
TOTAL	<u>\$271,654</u>	<u>\$203,750</u>	<u>\$224,938</u>	<u>\$0</u>	<u>\$224,938</u>
TOTAL POSITIONS	5	5	5	0	5

MOHEGAN C.C.
ADMINISTRATIVE DP PLAN

INSTITUTIONAL EXPENDITURE SUMMARY

	87/88 CURRENT YEAR	88/89 BUDGETED YEAR	PLAN YEAR 1 (89/90)		
			EXPEND. BASE	REQUIRED NEW FUNDS	TOTAL
<u>GENERAL FUND</u>					
Personal Services					
Positions	2	2	2	0	2
Cost	\$51,812	\$54,403	\$57,123	\$0	\$57,123
Other Expense					
Con't	\$7,232	\$7,232	\$7,594	\$0	\$7,594
Nonrecurring	\$0	\$0	\$0	\$0	\$0
Equipment	\$1,586	\$0	\$0	\$0	\$0
SUBTOTAL	\$60,630	\$61,635	\$64,716	\$0	\$64,716
<u>TUITION FUND</u>					
Personal Services					
Positions	0	0	0	0	0
Cost	\$0	\$0	\$0	\$0	\$0
Other Expense					
Con't	\$11,746	\$11,746	\$12,333	\$0	\$12,333
Nonrecurring	\$0	\$0	\$0	\$0	\$0
Equipment	\$13,757	\$8,000	\$8,000	\$0	\$8,000
SUBTOTAL	\$25,503	\$19,746	\$20,333	\$0	\$20,333
EXTENSION FUND	\$1,835	\$0	\$0	\$0	\$0
AUXILIARY SERVICES	\$0	\$0	\$0	\$0	\$0
FEDERAL FUNDS	\$0	\$0	\$0	\$0	\$0
OTHER	\$0	\$14,000	\$14,000	\$0	\$14,000
TOTAL	<u>\$87,968</u>	<u>\$95,381</u>	<u>\$99,050</u>	<u>\$0</u>	<u>\$99,050</u>
TOTAL POSITIONS	2	2	2	0	2

MATTATUCK C.C.
ADMINISTRATIVE DP PLAN

INSTITUTIONAL EXPENDITURE SUMMARY

	87/88 CURRENT YEAR	88/89 BUDGETED YEAR	PLAN YEAR 1 (89/90)		
			EXPEND. BASE	REQUIRED NEW FUNDS	TOTAL
<u>GENERAL FUND</u>					
Personal Services					
Positions	2	2	2	0	2
Cost	\$53,681	\$56,365	\$59,183	\$0	\$59,183
Other Expense					
Con't	\$13,807	\$13,807	\$14,497	\$0	\$14,497
Nonrecurring	\$0	\$0	\$0	\$0	\$0
Equipment	\$8,770	\$0	\$0	\$0	\$0
SUBTOTAL	\$76,258	\$70,172	\$73,681	\$0	\$73,681
<u>TUITION FUND</u>					
Personal Services					
Positions	0	0	0	0	0
Cost	\$0	\$0	\$0	\$0	\$0
Other Expense					
Con't	\$14,717	\$14,717	\$15,453	\$0	\$15,453
Nonrecurring	\$0	\$0	\$0	\$0	\$0
Equipment	\$11,202	\$15,000	\$20,000	\$0	\$20,000
SUBTOTAL	\$25,919	\$29,717	\$35,453	\$0	\$35,453
EXTENSION FUND	\$0	\$0	\$0	\$0	\$0
AUXILIARY SERVICES	\$0	\$0	\$0	\$0	\$0
FEDERAL FUNDS	\$0	\$0	\$0	\$0	\$0
OTHER	\$0	\$0	\$0	\$0	\$0
TOTAL	<u>\$102,177</u>	<u>\$99,889</u>	<u>\$109,134</u>	<u>\$0</u>	<u>\$109,134</u>
TOTAL POSITIONS	2	2	2	0	2

MIDDLESEX C.C.
ADMINISTRATIVE DP PLAN

INSTITUTIONAL EXPENDITURE SUMMARY

	87/88 CURRENT YEAR	88/89 BUDGETED YEAR	PLAN YEAR 1 (89/90)		
			EXPEND. BASE	REQUIRED NEW FUNDS	TOTAL
<u>GENERAL FUND</u>					
Personal Services					
Positions	2	2	2	0	2
Cost	\$55,980	\$58,779	\$61,718	\$0	\$61,718
Other Expense					
Con't	\$0	\$4,500	\$4,725	\$0	\$4,725
Nonrecurring	\$0	\$0	\$0	\$0	\$0
Equipment	\$8,631	\$0	\$8,000	\$0	\$8,000
SUBTOTAL	\$64,611	\$63,279	\$74,443	\$0	\$74,443
<u>TUITION FUND</u>					
Personal Services					
Positions	0	0	0	0	0
Cost	\$0	\$0	\$0	\$0	\$0
Other Expense					
Con't	\$13,829	\$13,829	\$14,520	\$0	\$14,520
Nonrecurring	\$0	\$0	\$0	\$0	\$0
Equipment	\$11,890	\$9,454	\$12,000	\$0	\$12,000
SUBTOTAL	\$25,719	\$23,283	\$26,520	\$0	\$26,520
EXTENSION FUND	\$0	\$0	\$0	\$0	\$0
AUXILIARY SERVICES	\$0	\$0	\$0	\$0	\$0
FEDERAL FUNDS	\$0	\$0	\$0	\$0	\$0
OTHER	\$0	\$0	\$0	\$0	\$0
TOTAL	<u>\$90,330</u>	<u>\$86,562</u>	<u>\$100,963</u>	<u>\$0</u>	<u>\$100,963</u>
TOTAL POSITIONS	2	2	2	0	2

NORWALK C.C.
ADMINISTRATIVE DP PLAN

INSTITUTIONAL EXPENDITURE SUMMARY

	87/88 CURRENT YEAR	88/89 BUDGETED YEAR	PLAN YEAR 1 (89/90)		
			EXPEND. BASE	REQUIRED NEW FUNDS	TOTAL
<u>GENERAL FUND</u>					
Personal Services					
Positions	2	2	2	0	2
Cost	\$63,673	\$66,857	\$70,199	\$0	\$70,199
Other Expense					
Con't	\$3,327	\$4,500	\$4,725	\$0	\$4,725
Nonrecurring	\$0	\$0	\$0	\$0	\$0
Equipment	\$16,644	\$0	\$0	\$0	\$0
SUBTOTAL	\$83,644	\$71,357	\$74,924	\$0	\$74,924
<u>TUITION FUND</u>					
Personal Services					
Positions	0	0	0	0	0
Cost	\$0	\$0	\$0	\$0	\$0
Other Expense					
Con't	\$20,101	\$20,101	\$21,106	\$0	\$21,106
Nonrecurring	\$0	\$0	\$0	\$0	\$0
Equipment	\$0	\$0	\$0	\$0	\$0
SUBTOTAL	\$20,101	\$20,101	\$21,106	\$0	\$21,106
EXTENSION FUND	\$0	\$0	\$0	\$0	\$0
AUXILIARY SERVICES	\$2,168	\$0	\$0	\$0	\$0
FEDERAL FUNDS	\$0	\$0	\$0	\$0	\$0
OTHER	\$0	\$0	\$0	\$0	\$0
TOTAL	<u>\$105,913</u>	<u>\$91,458</u>	<u>\$96,031</u>	<u>\$0</u>	<u>\$96,031</u>
TOTAL POSITIONS	2	2	2	0	2

NORTHWESTERN C.C.
ADMINISTRATIVE DP PLAN

INSTITUTIONAL EXPENDITURE SUMMARY

	87/88 CURRENT YEAR	88/89 BUDGETED YEAR	PLAN YEAR 1 (89/90)		
			EXPEND. BASE	REQUIRED NEW FUNDS	TOTAL
<u>GENERAL FUND</u>					
Personal Services					
Positions	2	2	2	0	2
Cost	\$48,040	\$50,442	\$52,964	\$0	\$52,964
Other Expense					
Con't	\$0	\$4,500	\$4,725	\$0	\$4,725
Nonrecurring	\$0	\$0	\$0	\$0	\$0
Equipment	\$17,150	\$0	\$0	\$0	\$0
SUBTOTAL	\$65,190	\$54,942	\$57,689	\$0	\$57,689
<u>TUITION FUND</u>					
Personal Services					
Positions	0	0	0	0	0
Cost	\$0	\$0	\$0	\$0	\$0
Other Expense					
Con't	\$12,851	\$12,851	\$13,494	\$0	\$13,494
Nonrecurring	\$0	\$0	\$0	\$0	\$0
Equipment	\$0	\$0	\$0	\$0	\$0
SUBTOTAL	\$12,851	\$12,851	\$13,494	\$0	\$13,494
EXTENSION FUND	\$0	\$0	\$0	\$0	\$0
AUXILIARY SERVICES	\$0	\$0	\$0	\$0	\$0
FEDERAL FUNDS	\$0	\$0	\$0	\$0	\$0
OTHER	\$0	\$0	\$0	\$0	\$0
TOTAL	<u>\$78,041</u>	<u>\$67,793</u>	<u>\$71,183</u>	\$0	<u>\$71,183</u>
TOTAL POSITIONS	2	2	2	0	2

QUINEBAUG VALLEY C.C.
ADMINISTRATIVE DP PLAN

INSTITUTIONAL EXPENDITURE SUMMARY

	87/88 CURRENT YEAR	88/89 BUDGETED YEAR	PLAN YEAR 1 (89/90)		
			EXPEND. BASE	REQUIRED NEW FUNDS	TOTAL
<u>GENERAL FUND</u>					
Personal Services					
Positions	0	0	0	0	0
Cost	\$0	\$0	\$0	\$0	\$0
Other Expense					
Con't	\$2,858	\$4,500	\$4,725	\$0	\$4,725
Nonrecurring	\$0	\$0	\$0	\$0	\$0
Equipment	\$20,460	\$6,500	\$18,950	\$0	\$18,950
SUBTOTAL	\$23,318	\$11,000	\$23,675	\$0	\$23,675
<u>TUITION FUND</u>					
Personal Services					
Positions	0	0	0	0	0
Cost	\$0	\$0	\$0	\$0	\$0
Other Expense					
Con't	\$4,966	\$4,966	\$5,214	\$0	\$5,214
Nonrecurring	\$0	\$0	\$0	\$0	\$0
Equipment	\$0	\$0	\$0	\$0	\$0
SUBTOTAL	\$4,966	\$4,966	\$5,214	\$0	\$5,214
EXTENSION FUND	\$0	\$0	\$0	\$0	\$0
AUXILIARY SERVICES	\$0	\$0	\$0	\$0	\$0
FEDERAL FUNDS	\$0	\$0	\$0	\$0	\$0
OTHER	\$0	\$0	\$0	\$0	\$0
TOTAL	<u>\$28,284</u>	<u>\$15,966</u>	<u>\$28,889</u>	<u>\$0</u>	<u>\$23,889</u>
TOTAL POSITIONS	0	0	0	0	0

SOUTH CENTRAL C.C.
ADMINISTRATIVE DP PLAN

INSTITUTIONAL EXPENDITURE SUMMARY

	87/88 CURRENT YEAR	88/89 BUDGETED YEAR	PLAN YEAR 1 (89/90)		
			EXPEND. BASE	REQUIRED NEW FUNDS	TOTAL
<u>GENERAL FUND</u>					
Personal Services Positions	3	3	3	0	3
Cost	\$83,081	\$87,235	\$91,597	\$0	\$91,597
Other Expense Con't	\$0	\$4,500	\$4,725	\$0	\$4,725
Nonrecurring Equipment	\$0	\$0	\$0	\$0	\$0
	\$6,011	\$0	\$0	\$0	\$0
SUBTOTAL	\$89,092	\$91,735	\$96,322	\$0	\$96,322
<u>TUITION FUND</u>					
Personal Services Positions	0	0	0	0	0
Cost	\$0	\$0	\$0	\$0	\$0
Other Expense Con't	\$7,130	\$7,130	\$7,130	\$0	\$7,130
Nonrecurring Equipment	\$0	\$0	\$0	\$0	\$0
	\$1,180	\$0	\$10,000	\$0	\$10,000
SUBTOTAL	\$8,310	\$7,130	\$17,130	\$0	\$17,130
EXTENSION FUND	\$0	\$0	\$0	\$0	\$0
AUXILIARY SERVICES	\$23,688	\$0	\$0	\$0	\$0
FEDERAL FUNDS	\$0	\$0	\$0	\$0	\$0
OTHER	\$0	\$0	\$0	\$0	\$0
TOTAL	\$121,090	\$98,865	\$113,452	\$0	\$113,452
TOTAL POSITIONS	3	3	3	0	3

TUNXIS C.C.
ADMINISTRATIVE DP PLAN

INSTITUTIONAL EXPENDITURE SUMMARY

	87/88 CURRENT YEAR	88/89 BUDGETED YEAR	PLAN YEAR 1 (89/90)		
			EXPEND. BASE	REQUIRED NEW FUNDS	TOTAL
GENERAL FUND					
Personal Services					
Positions	2	2	2	0	2
Cost	\$56,246	\$59,058	\$62,011	\$0	\$62,011
Other Expense					
Con't	\$17,125	\$17,125	\$17,981	\$0	\$17,981
Nonrecurring	\$0	\$0	\$0	\$0	\$0
Equipment	\$17,150	\$0	\$0	\$0	\$0
SUBTOTAL	\$90,521	\$76,183	\$79,992	\$0	\$79,992
TUITION FUND					
Personal Services					
Positions	0	0	0	0	0
Cost	\$0	\$0	\$0	\$0	\$0
Other Expense					
Con't	\$13,820	\$13,820	\$14,511	\$0	\$14,511
Nonrecurring	\$0	\$0	\$0	\$0	\$0
Equipment	\$2,912	\$24,605	\$21,000	\$0	\$21,000
SUBTOTAL	\$16,732	\$38,425	\$35,511	\$0	\$35,511
EXTENSION FUND	\$0	\$0	\$0	\$0	\$0
AUXILIARY SERVICES	\$0	\$0	\$0	\$0	\$0
FEDERAL FUNDS	\$0	\$0	\$0	\$0	\$0
OTHER	\$0	\$0	\$0	\$0	\$0
TOTAL	\$107,253	\$114,608	\$115,503	\$0	\$115,503
TOTAL POSITIONS	2	2	2	0	2

REGIONAL COMMUNITY COLLEGES
ACADEMIC DP PLAN

INSTITUTIONAL EXPENDITURE SUMMARY

	87/88 CURRENT YEAR	88/89 BUDGETED YEAR	PLAN YEAR 1 (89/90)		TOTAL
			EXPEND. BASE	REQUIRED NEW FUNDS	
GENERAL FUND					
Personal Services					
Positions	14	14	14	2	16
Cost	\$249,645	\$262,127	\$275,234	\$51,466	\$326,700
Other Expense					
Con't	\$41,836	\$72,015	\$75,616	\$0	\$75,616
Nonrecurring	\$0	\$0	\$0	\$0	\$0
Equipment	\$49,044	\$6,000	\$6,000	\$0	\$6,000
SUBTOTAL	\$340,525	\$340,142	\$356,849	\$51,466	\$408,315
TUITION FUND					
Personal Services					
Positions	0	0	0	0	0
Cost	\$0	\$0	\$0	\$0	\$0
Other Expense					
Con't	\$240,999	\$240,999	\$253,049	\$0	\$253,049
Nonrecurring	\$0	\$0	\$0	\$0	\$0
Equipment	\$394,908	\$467,754	\$470,027	\$0	\$470,027
SUBTOTAL	\$635,907	\$708,753	\$723,076	\$0	\$723,076
EXTENSION FUND	\$24,564	\$31,000	\$21,000	\$0	\$21,000
AUXILIARY SERVICES	\$16,636	\$9,169	\$7,528	\$0	\$7,528
FEDERAL FUNDS	\$46,341	\$61,506	\$37,656	\$0	\$37,656
OTHER	\$226,611	\$161,357	\$18,672	\$0	\$18,672
TOTAL	\$1,290,584	\$1,311,927	\$1,164,781	\$51,466	\$1,216,247
TOTAL POSITIONS	14	14	14	2	16

BOARD OF TRUSTEES
ACADEMIC DP PLAN

INSTITUTIONAL EXPENDITURE SUMMARY

	87/88 CURRENT YEAR	88/89 BUDGETED YEAR	PLAN YEAR 1		(89/90) TOTAL
			EXPEND. BASE	REQUIRED NEW FUNDS	
GENERAL FUND					
Personal Services					
Positions	0	0	0	0	0
Cost	\$0	\$0	\$0	\$0	\$0
Other Expense					
Con't	\$0	\$0	\$0	\$0	\$0
Nonrecurring	\$0	\$0	\$0	\$0	\$0
Equipment	\$0	\$0	\$0	\$0	\$0
SUBTOTAL	\$0	\$0	\$0	\$0	\$0
TUITION FUND					
Personal Services					
Positions	0	0	0	0	0
Cost	\$0	\$0	\$0	\$0	\$0
Other Expense					
Con't	\$45,000	\$45,000	\$47,250	\$0	\$47,250
Nonrecurring	\$0	\$0	\$0	\$0	\$0
Equipment	\$135,000	\$195,000	\$195,000	\$0	\$195,000
SUBTOTAL	\$180,000	\$240,000	\$242,250	\$0	\$242,250
EXTENSION FUND	\$0	\$0	\$0	\$0	\$0
AUXILIARY SERVICES	\$0	\$0	\$0	\$0	\$0
FEDERAL FUNDS	\$0	\$0	\$0	\$0	\$0
OTHER	\$200,000	\$125,300	\$0	\$0	\$0
TOTAL	\$380,000	\$365,300	\$242,250	\$0	\$242,250
TOTAL POSITIONS	0	0	0	0	0

ASNUNTUCK C.C.
ACADEMIC DP PLAN

INSTITUTIONAL EXPENDITURE SUMMARY

	87/88 CURRENT YEAR	88/89 BUDGETED YEAR	PLAN YEAR 1 (89/90)		
			EXPEND. BASE	REQUIRED NEW FUNDS	TOTAL
GENERAL FUND					
Personal Services					
Positions	2	2	2	0	2
Cost	\$48,604	\$51,034	\$53,586	\$0	\$53,586
Other Expense					
Con't	\$1,247	\$4,500	\$4,725	\$0	\$4,725
Nonrecurring	\$0	\$0	\$0	\$0	\$0
Equipment	\$0	\$0	\$0	\$0	\$0
SUBTOTAL	\$49,851	\$55,534	\$58,311	\$0	\$58,311
TUITION FUND					
Personal Services					
Positions	0	0	0	0	0
Cost	\$0	\$0	\$0	\$0	\$0
Other Expense					
Con't	\$59,284	\$59,284	\$62,248	\$0	\$62,248
Nonrecurring	\$0	\$0	\$0	\$0	\$0
Equipment	\$26,875	\$28,219	\$29,630	\$0	\$29,630
SUBTOTAL	\$86,159	\$87,503	\$91,878	\$0	\$91,878
EXTENSION FUND	\$0	\$0	\$0	\$0	\$0
AUXILIARY SERVICES	\$6,828	\$7,169	\$7,528	\$0	\$7,528
FEDERAL FUNDS	\$0	\$0	\$0	\$0	\$0
OTHER	\$0	\$0	\$0	\$0	\$0
TOTAL	<u>\$142,838</u>	<u>\$150,206</u>	<u>\$157,717</u>	\$0	<u>\$157,717</u>
TOTAL POSITIONS	2	2	2	0	2

GREATER HARTFORD C.C.
ACADEMIC DP PLAN

INSTITUTIONAL EXPENDITURE SUMMARY

	87/88 CURRENT YEAR	88/89 BUDGETED YEAR	PLAN YEAR 1 (89/90)		
			EXPEND. BASE	REQUIRED NEW FUNDS	TOTAL
GENERAL FUND					
Personal Services					
Positions					
Cost	2	2	2	0	2
\$32,607		\$34,237	\$35,949	\$0	\$35,949
Other Expense					
Con't	\$5,538	\$5,538	\$5,815	\$0	\$5,815
Nonrecurring	\$0	\$0	\$0	\$0	\$0
Equipment	\$1,526	\$0	\$0	\$0	\$0
SUBTOTAL	\$39,671	\$39,775	\$41,764	\$0	\$41,764
TUITION FUND					
Personal Services					
Positions	0	0	0	0	0
Cost	\$0	\$0	\$0	\$0	\$0
Other Expense					
Con't	\$24,050	\$24,050	\$25,253	\$0	\$25,253
Nonrecurring	\$0	\$0	\$0	\$0	\$0
Equipment	\$10,476	\$12,000	\$13,000	\$0	\$13,000
SUBTOTAL	\$34,526	\$36,050	\$38,253	\$0	\$38,253
EXTENSION FUND	\$10,317	\$11,000	\$11,000	\$0	\$11,000
AUXILIARY SERVICES	\$1,789	\$0	\$0	\$0	\$0
FEDERAL FUNDS	\$0	\$0	\$0	\$0	\$0
OTHER	\$0	\$0	\$0	\$0	\$0
TOTAL	\$86,803	\$86,825	\$91,017	\$0	\$91,017
TOTAL POSITIONS	2	2	2	0	2

HOUSATONIC C.C.
ACADEMIC DP PLAN

INSTITUTIONAL EXPENDITURE SUMMARY

	87/88 CURRENT YEAR	88/89 BUDGETED YEAR	PLAN YEAR 1 (89/90)		
			EXPEND. BASE	REQUIRED NEW FUNDS	TOTAL
GENERAL FUND					
Personal Services					
Positions	1	1	1	0	1
Cost	\$15,662	\$16,445	\$17,267	\$0	\$17,267
Other Expense					
Con't	\$437	\$4,500	\$4,725	\$0	\$4,725
Nonrecurring	\$0	\$0	\$0	\$0	\$0
Equipment	\$13,663	\$0	\$0	\$0	\$0
SUBTOTAL	\$29,762	\$20,945	\$21,992	\$0	\$21,992
TUITION FUND					
Personal Services					
Positions	0	0	0	0	0
Cost	\$0	\$0	\$0	\$0	\$0
Other Expense					
Con't	\$4,567	\$4,567	\$4,795	\$0	\$4,795
Nonrecurring	\$0	\$0	\$0	\$0	\$0
Equipment	\$16,784	\$24,000	\$24,000	\$0	\$24,000
SUBTOTAL	\$21,351	\$28,567	\$28,795	\$0	\$28,795
EXTENSION FUND	\$0	\$0	\$0	\$0	\$0
AUXILIARY SERVICES	\$0	\$0	\$0	\$0	\$0
FEDERAL FUNDS	\$13,248	\$12,000	\$10,000	\$0	\$10,000
OTHER	\$0	\$0	\$0	\$0	\$0
TOTAL	\$64,361	\$61,512	\$60,788	\$0	\$60,788
TOTAL POSITIONS	1	1	1	0	1

MANCHESTER C.C.
ACADEMIC DP PLAN

INSTITUTIONAL EXPENDITURE SUMMARY

	87/88 CURRENT YEAR	88/89 BUDGETED YEAR	PLAN YEAR 1 (89/90)		
			EXPEND. BASE	REQUIRED NEW FUNDS	TOTAL
<u>GENERAL FUND</u>					
Personal Services Positions					
Cost	2 \$25,092	2 \$26,347	2 \$27,664	0 \$0	2 \$27,664
Other Expense Con't	\$17,858	\$17,858	\$18,751	\$0	\$18,751
Nonrecurring	\$0	\$0	\$0	\$0	\$0
Equipment	\$0	\$0	\$0	\$0	\$0
SUBTOTAL	\$42,950	\$44,205	\$46,415	\$0	\$46,415
<u>TUITION FUND</u>					
Personal Services Positions					
Cost	0 \$0	0 \$0	0 \$0	0 \$0	0 \$0
Other Expense Con't	\$38,537	\$38,537	\$40,464	\$0	\$40,464
Nonrecurring	\$0	\$0	\$0	\$0	\$0
Equipment	\$44,916	\$47,162	\$49,520	\$0	\$49,520
SUBTOTAL	\$83,453	\$85,699	\$89,984	\$0	\$89,984
EXTENSION FUND	\$0	\$0	\$0	\$0	\$0
AUXILIARY SERVICES	\$0	\$0	\$0	\$0	\$0
FEDERAL FUNDS	\$4,086	\$8,000	\$0	\$0	\$0
OTHER	\$3,990	\$3,725	\$6,350	\$0	\$6,350
TOTAL	<u>\$134,479</u>	<u>\$141,629</u>	<u>\$142,749</u>	<u>\$0</u>	<u>\$142,749</u>
TOTAL POSITIONS	2	2	2	0	2

MOHEGAN C.C.
ACADEMIC DP PLAN

INSTITUTIONAL EXPENDITURE SUMMARY

	87/88 CURRENT YEAR	88/89 BUDGETED YEAR	PLAN YEAR 1 (89/90)		
			EXPEND. BASE	REQUIRED NEW FUNDS	TOTAL
GENERAL FUND					
Personal Services					
Positions	1	1	1	0	1
Cost	\$21,109	\$22,164	\$23,273	\$0	\$23,273
Other Expense					
Con't	\$2,100	\$4,500	\$4,725	\$0	\$4,725
Nonrecurring	\$0	\$0	\$0	\$0	\$0
Equipment	\$5,557	\$6,000	\$6,000	\$0	\$6,000
SUBTOTAL	\$28,766	\$32,664	\$33,998	\$0	\$33,998
TUITION FUND					
Personal Services					
Positions	0	0	0	0	0
Cost	\$0	\$0	\$0	\$0	\$0
Other Expense					
Con't	\$5,479	\$5,479	\$5,753	\$0	\$5,753
Nonrecurring	\$0	\$0	\$0	\$0	\$0
Equipment	\$10,839	\$12,000	\$12,000	\$0	\$12,000
SUBTOTAL	\$16,318	\$17,479	\$17,753	\$0	\$17,753
EXTENSION FUND	\$8,732	\$0	\$0	\$0	\$0
AUXILIARY SERVICES	\$0	\$0	\$0	\$0	\$0
FEDERAL FUNDS	\$0	\$0	\$0	\$0	\$0
OTHER	\$10,261	\$20,000	\$0	\$0	\$0
TOTAL	\$64,077	\$70,143	\$51,751	\$0	\$51,751
TOTAL POSITIONS	1	1	1	0	1

MATTATUCK C.C.
ACADEMIC DP PLAN

INSTITUTIONAL EXPENDITURE SUMMARY

	87/88 CURRENT YEAR	88/89 BUDGETED YEAR	PLAN YEAR 1 (89/90)		
			EXPEND. BASE	REQUIRED NEW FUNDS	TOTAL
GENERAL FUND					
Personal Services Positions	1	1	1	0	1
Cost	\$21,109	\$22,164	\$23,273	\$0	\$23,273
Other Expense Con't	\$674	\$4,500	\$4,725	\$0	\$4,725
Nonrecurring	\$0	\$0	\$0	\$0	\$0
Equipment	\$0	\$0	\$0	\$0	\$0
SUBTOTAL	\$21,783	\$26,664	\$27,998	\$0	\$27,998
TUITION FUND					
Personal Services Positions	0	0	0	0	0
Cost	\$0	\$0	\$0	\$0	\$0
Other Expense Con't	\$7,609	\$7,609	\$7,989	\$0	\$7,989
Nonrecurring	\$0	\$0	\$0	\$0	\$0
Equipment	\$7,840	\$20,000	\$30,000	\$0	\$30,000
SUBTOTAL	\$15,449	\$27,609	\$37,989	\$0	\$37,989
EXTENSION FUND	\$0	\$0	\$0	\$0	\$0
AUXILIARY SERVICES	\$0	\$0	\$0	\$0	\$0
FEDERAL FUNDS	\$17,699	\$3,000	\$16,150	\$0	\$16,150
OTHER	\$0	\$0	\$0	\$0	\$0
TOTAL	\$54,931	\$84,273	\$82,137	\$0	\$82,137
TOTAL POSITIONS	1	1	1	0	1

MIDDLESEX C.C.
ACADEMIC DP PLAN

INSTITUTIONAL EXPENDITURE SUMMARY

	87/88 CURRENT YEAR	88/89 BUDGETED YEAR	PLAN YEAR 1 (89/90)		
			EXPEND. BASE	REQUIRED NEW FUNDS	TOTAL
GENERAL FUND					
Personal Services					
Positions	2	2	2	1	3
Cost	\$28,988	\$30,437	\$31,959	\$15,524	\$47,483
Other Expense					
Con't	\$0	\$4,500	\$4,725	\$0	\$4,725
Nonrecurring	\$0	\$0	\$0	\$0	\$0
Equipment	\$7,777	\$0	\$0	\$0	\$0
SUBTOTAL	\$36,765	\$34,937	\$36,684	\$15,524	\$52,208
TUITION FUND					
Personal Services					
Positions	0	0	0	0	0
Cost	\$0	\$0	\$0	\$0	\$0
Other Expense					
Con't	\$8,872	\$8,872	\$9,316	\$0	\$9,316
Nonrecurring	\$0	\$0	\$0	\$0	\$0
Equipment	\$6,111	\$3,500	\$4,000	\$0	\$4,000
SUBTOTAL	\$14,983	\$12,372	\$13,316	\$0	\$13,316
EXTENSION FUNDS	\$1,590	\$0	\$0	\$0	\$0
AUXILIARY SERVICES	\$0	\$0	\$0	\$0	\$0
FEDERAL FUNDS	\$0	\$0	\$0	\$0	\$0
OTHER	\$700	\$0	\$0	\$0	\$0
TOTAL	\$54,038	\$47,309	\$50,000	\$15,524	\$65,524
TOTAL POSITIONS	2	2	2	1	3

NORWALK C.C.
ACADEMIC DP PLAN

INSTITUTIONAL EXPENDITURE SUMMARY

	87/88 CURRENT YEAR	88/89 BUDGETED YEAR	PLAN YEAR 1 (89/90)		
			EXPEND. BASE	REQUIRED NEW FUNDS	TOTAL
<u>GENERAL FUND</u>					
Personal Services					
Positions	2	2	2	0	2
Cost	\$38,884	\$40,828	\$42,870	\$0	\$42,870
Other Expense					
Con't	\$4,619	\$4,619	\$4,850	\$0	\$4,850
Nonrecurring	\$0	\$0	\$0	\$0	\$0
Equipment	\$0	\$0	\$0	\$0	\$0
SUBTOTAL	\$43,503	\$45,447	\$47,720	\$0	\$47,720
<u>TUITION FUND</u>					
Personal Services					
Positions	0	0	0	0	0
Cost	\$0	\$0	\$0	\$0	\$0
Other Expense					
Con't	\$8,087	\$8,087	\$8,491	\$0	\$8,491
Nonrecurring	\$0	\$0	\$0	\$0	\$0
Equipment	\$26,295	\$26,295	\$26,295	\$0	\$26,295
SUBTOTAL	\$34,382	\$34,382	\$34,786	\$0	\$34,786
EXTENSION FUND	\$0	\$0	\$0	\$0	\$0
AUXILIARY SERVICES	\$8,019	\$0	\$0	\$0	\$0
FEDERAL FUNDS	\$8,152	\$8,338	\$8,338	\$0	\$8,338
OTHER	\$11,660	\$0	\$0	\$0	\$0
TOTAL	\$105,716	\$88,167	\$90,844	\$0	\$90,844
TOTAL POSITIONS	2	2	2	0	2

NORTHWESTERN C.C.
ACADEMIC DP PLAN

INSTITUTIONAL EXPENDITURE SUMMARY

	87/88 CURRENT YEAR	88/89 BUDGETED YEAR	PLAN YEAR 1 (89/90)		
			EXPEND. BASE	REQUIRED NEW FUNDS	TOTAL
GENERAL FUND					
Personal Services					
Positions	1	1	1	0	1
Cost	\$17,590	\$18,470	\$19,393	\$0	\$19,393
Other Expense					
Con't	\$0	\$4,500	\$4,725	\$0	\$4,725
Nonrecurring	\$0	\$0	\$0	\$0	\$0
Equipment	\$12,040	\$0	\$0	\$0	\$0
SUBTOTAL	\$29,630	\$22,970	\$24,118	\$0	\$24,118
TUITION FUND					
Personal Services					
Positions	0	0	0	0	0
Cost	\$0	\$0	\$0	\$0	\$0
Other Expense					
Con't	\$14,025	\$14,025	\$14,726	\$0	\$14,726
Nonrecurring	\$0	\$0	\$0	\$0	\$0
Equipment	\$20,232	\$20,232	\$20,232	\$0	\$20,232
SUBTOTAL	\$34,257	\$34,257	\$34,958	\$0	\$34,958
EXTENSION FUND	\$0	\$0	\$0	\$0	\$0
AUXILIARY SERVICES	\$0	\$0	\$0	\$0	\$0
FEDERAL FUNDS	\$0	\$0	\$0	\$0	\$0
OTHER	\$0	\$0	\$0	\$0	\$0
TOTAL	\$63,887	\$57,227	\$59,076	\$0	\$59,076
TOTAL POSITIONS	1	1	1	0	1

QUINEBAUG VALLEY C.C.
ACADEMIC DP PLAN

INSTITUTIONAL EXPENDITURE SUMMARY

	87/88 CURRENT YEAR	88/89 BUDGETED YEAR	PLAN YEAR 1 (89/90)		
			EXPEND. BASE	REQUIRED NEW FUNDS	TOTAL
GENERAL FUND					
Personal Services					
Positions	0	0	0	1	1
Cost	\$0	\$0	\$0	\$35,942	\$35,942
Other Expense					
Con't	\$8,000	\$8,000	\$8,400	\$0	\$8,400
Nonrecurring	\$0	\$0	\$0	\$0	\$0
Equipment	\$0	\$0	\$0	\$0	\$0
SUBTOTAL	\$8,000	\$8,000	\$8,400	\$35,942	\$44,342
TUITION FUND					
Personal Services					
Positions	0	0	0	0	0
Cost	\$0	\$0	\$0	\$0	\$0
Other Expense					
Con't	\$0	\$0	\$0	\$0	\$0
Nonrecurring	\$0	\$0	\$0	\$0	\$0
Equipment	\$42,308	\$3,000	\$20,350	\$0	\$20,350
SUBTOTAL	\$42,308	\$3,000	\$20,350	\$0	\$20,350
EXTENSION FUND	\$0	\$0	\$0	\$0	\$0
AUXILIARY SERVICES	\$0	\$0	\$0	\$0	\$0
FEDERAL FUNDS	\$3,156	\$3,168	\$3,168	\$0	\$3,168
OTHER	\$0	\$12,332	\$12,322	\$0	\$12,322
TOTAL	<u>\$53,464</u>	<u>\$26,500</u>	<u>\$44,240</u>	<u>\$35,942</u>	<u>\$80,182</u>
TOTAL POSITIONS	0	0	0	1	1

SOUTH CENTRAL C.C.
ACADEMIC DP PLAN

INSTITUTIONAL EXPENDITURE SUMMARY

	87/88 CURRENT YEAR	88/89 BUDGETED YEAR	PLAN YEAR 1 (89/90)		
			EXPEND. BASE	REQUIRED NEW FUNDS	TOTAL
<u>GENERAL FUND</u>					
Personal Services					
Positions	0	0	0	0	0
Cost	\$0	\$0	\$0	\$0	\$0
Other Expense					
Con't	\$1,363	\$4,500	\$4,725	\$0	\$4,725
Nonrecurring	\$0	\$0	\$0	\$0	\$0
Equipment	\$0	\$0	\$0	\$0	\$0
SUBTOTAL	\$1,363	\$4,500	\$4,725	\$0	\$4,725
<u>TUITION FUND</u>					
Personal Services					
Positions	0	0	0	0	0
Cost	\$0	\$0	\$0	\$0	\$0
Other Expense					
Con't	\$7,772	\$7,772	\$8,161	\$0	\$8,161
Nonrecurring	\$0	\$0	\$0	\$0	\$0
Equipment	\$28,276	\$25,000	\$30,000	\$0	\$30,000
SUBTOTAL	\$36,048	\$32,772	\$38,161	\$0	\$38,161
EXTENSION FUND	\$0	\$0	\$0	\$0	\$0
AUXILIARY SERVICES	\$0	\$0	\$0	\$0	\$0
FEDERAL FUNDS	\$0	\$0	\$0	\$0	\$0
OTHER	\$0	\$0	\$0	\$0	\$0
TOTAL	\$37,411	\$37,272	\$42,886	\$0	\$42,886
TOTAL POSITIONS	0	0	0	0	0

TUNXIS C.C.
ACADEMIC DP PLAN

INSTITUTIONAL EXPENDITURE SUMMARY

	87/88 CURRENT YEAR	88/89 BUDGETED YEAR	PLAN YEAR 1 (89/90)		
			EXPEND. BASE	REQUIRED NEW FUNDS	TOTAL
GENERAL FUND					
Personal Services					
Positions	0	0	0	0	0
Cost	\$0	\$0	\$0	\$0	\$0
Other Expense					
Con't	\$0	\$4,500	\$4,725	\$0	\$4,725
Nonrecurring	\$0	\$0	\$0	\$0	\$0
Equipment	\$8,481	\$0	\$0	\$0	\$0
SUBTOTAL	\$8,481	\$4,500	\$4,725	\$0	\$4,725
TUITION FUND					
Personal Services					
Positions	0	0	0	0	0
Cost	\$0	\$0	\$0	\$0	\$0
Other Expense					
Con't	\$17,717	\$17,717	\$18,603	\$0	\$18,603
Nonrecurring	\$0	\$0	\$0	\$0	\$0
Equipment	\$18,956	\$51,346	\$16,000	\$0	\$16,000
SUBTOTAL	\$36,673	\$69,063	\$34,603	\$0	\$34,603
EXTENSION FUND	\$3,425	\$20,000	\$10,000	\$0	\$10,000
AUXILIARY SERVICES	\$0	\$2,000	\$0	\$0	\$0
FEDERAL FUNDS	\$0	\$0	\$0	\$0	\$0
OTHER	\$0	\$0	\$0	\$0	\$0
TOTAL	\$48,579	\$95,563	\$49,328	\$0	\$49,328
TOTAL POSITIONS	0	0	0	0	0

REGIONAL COMMUNITY COLLEGES
SYSTEM EXPENDITURES

	87/88 CURRENT YEAR	88/89 BUDGETED YEAR	PLAN YEAR 1 (89/90)		TOTAL
			EXPEND. BASE	REQUIRED NEW FUNDS	
GENERAL FUND					
Personal Services Positions	49	49	49	3	52
Cost	\$1,259,816	\$1,322,807	\$1,388,947	\$83,166	\$1,472,113
Other Expense Con't	\$127,808	\$188,679	\$198,113	\$0	\$198,113
Nonrecurring	\$0	\$0	\$0	\$0	\$0
Equipment	\$276,593	\$39,889	\$61,309	\$0	\$61,309
SUBTOTAL	\$1,664,217	\$1,551,375	\$1,648,369	\$83,166	\$1,731,535
TUITION FUND					
Personal Services Positions	0	0	0	0	0
Cost	\$0	\$0	\$0	\$0	\$0
Other Expense Con't	\$453,369	\$453,369	\$475,681	\$0	\$475,681
Nonrecurring	\$0	\$0	\$0	\$0	\$0
Equipment	\$739,181	\$972,813	\$992,177	\$0	\$992,177
SUBTOTAL	\$1,192,550	\$1,426,182	\$1,467,858	\$0	\$1,467,858
EXTENSION FUND	\$26,399	\$31,000	\$32,000	\$0	\$32,000
AUXILIARY SERVICES	\$42,492	\$9,169	\$7,528	\$0	\$7,528
FEDERAL FUNDS	\$46,341	\$61,506	\$37,656	\$0	\$37,656
OTHER	\$230,305	\$175,357	\$32,672	\$0	\$32,672
TOTAL	\$3,202,304	\$3,254,589	\$3,226,063	\$83,166	\$3,309,249
TOTAL POSITIONS	49	49	49	3	52

BOARD OF TRUSTEES
ADMINISTRATIVE DP PLAN

INSTITUTIONAL EXPENDITURE SUMMARY

	87/88 CURRENT YEAR	88/89 BUDGETED YEAR	PLAN YEAR 1		(89/90) TOTAL
			EXPEND. BASE	REQUIRED NEW FUNDS	
GENERAL FUND					
Personal Services Positions	10	10	10	1	11
Cost	\$345,078	\$362,332	\$380,448	\$31,700	\$412,148
Other Expense Con't	\$37,000	\$38,000	\$39,900	\$0	\$39,900
Nonrecurring	\$0	\$0	\$0	\$0	\$0
Equipment	\$95,576	\$0	\$0	\$0	\$0
SUBTOTAL	\$477,654	\$400,332	\$420,348	\$31,700	\$452,048
TUITION FUND					
Personal Services Positions	0	0	0	0	0
Cost	\$0	\$0	\$0	\$0	\$0
Other Expense Con't	\$45,000	\$45,000	\$47,250	\$0	\$47,250
Nonrecurring	\$0	\$0	\$0	\$0	\$0
Equipment	\$194,968	\$405,000	\$405,000	\$0	\$405,000
SUBTOTAL	\$239,968	\$450,000	\$452,250	\$0	\$452,250
EXTENSION FUND	\$0	\$0	\$0	\$0	\$0
AUXILIARY SERVICES	\$0	\$0	\$0	\$0	\$0
FEDERAL FUNDS	\$0	\$0	\$0	\$0	\$0
OTHER	\$0	\$0	\$0	\$0	\$0
TOTAL	\$717,622	\$850,332	\$872,598	\$31,700	\$904,298
TOTAL POSITIONS	10	10	10	1	11

GREATER HARTFORD C.C.
ADMINISTRATIVE DP PLAN

INSTITUTIONAL EXPENDITURE SUMMARY

	87/88 CURRENT YEAR	88/89 BUDGETED YEAR	PLAN YEAR 1 (89/90)		
			EXPEND. BASE	REQUIRED NEW FUNDS	TOTAL
GENERAL FUND					
Personal Services Positions	3	3	3	0	3
Cost	\$76,674	\$80,508	\$84,533	\$0	\$84,533
Other Expense					
Con't	\$0	\$4,500	\$4,725	\$0	\$4,725
Nonrecurring	\$0	\$0	\$0	\$0	\$0
Equipment	\$7,509	\$8,000	\$8,000	\$0	\$8,000
SUBTOTAL	\$84,183	\$93,008	\$97,258	\$0	\$97,258
TUITION FUND					
Personal Services Positions	0	0	0	0	0
Cost	\$0	\$0	\$0	\$0	\$0
Other Expense					
Con't	\$11,136	\$11,136	\$11,693	\$0	\$11,693
Nonrecurring	\$0	\$0	\$0	\$0	\$0
Equipment	\$9,789	\$10,000	\$10,000	\$0	\$10,000
SUBTOTAL	\$20,925	\$21,136	\$21,693	\$0	\$21,693
EXTENSION FUND	\$0	\$0	\$0	\$0	\$0
AUXILIARY SERVICES	\$0	\$0	\$0	\$0	\$0
FEDERAL FUNDS	\$0	\$0	\$0	\$0	\$0
OTHER	\$3,694	\$0	\$0	\$0	\$0
TOTAL	\$108,802	\$114,144	\$118,951	\$0	\$118,951
TOTAL POSITIONS	3	3	3	0	3

**MANCHESTER C.C.
ADMINISTRATIVE DP PLAN**

INSTITUTIONAL EXPENDITURE SUMMARY

	87/88 CURRENT YEAR	88/89 BUDGETED YEAR	PLAN YEAR 1 (89/90)		
			EXPEND. BASE	REQUIRED NEW FUNDS	TOTAL
GENERAL FUND					
Personal Services					
Positions	5	5	5	0	5
Cost	\$124,923	\$131,169	\$137,728	\$0	\$137,728
Other Expense					
Con't	\$3,697	\$4,500	\$4,725	\$0	\$4,725
Nonrecurring	\$0	\$0	\$0	\$0	\$0
Equipment	\$15,807	\$7,500	\$7,875	\$0	\$7,875
SUBTOTAL	\$144,427	\$143,169	\$150,328	\$0	\$150,328
TUITION FUND					
Personal Services					
Positions	0	0	0	0	0
Cost	\$0	\$0	\$0	\$0	\$0
Other Expense					
Con't	\$37,581	\$37,581	\$39,460	\$0	\$39,460
Nonrecurring	\$0	\$0	\$0	\$0	\$0
Equipment	\$89,646	\$23,000	\$24,150	\$0	\$24,150
SUBTOTAL	\$127,227	\$60,581	\$63,610	\$0	\$63,610
EXTENSION FUND	\$0	\$0	\$11,000	\$0	\$11,000
AUXILIARY SERVICES	\$0	\$0	\$0	\$0	\$0
FEDERAL FUNDS	\$0	\$0	\$0	\$0	\$0
OTHER	\$0	\$0	\$0	\$0	\$0
TOTAL	\$271,654	\$203,750	\$224,938	\$0	\$224,938
TOTAL POSITIONS	5	5	5	0	5

MATTATUCK C.C.
ADMINISTRATIVE DP PLAN

INSTITUTIONAL EXPENDITURE SUMMARY

	87/88 CURRENT YEAR	88/89 BUDGETED YEAR	PLAN YEAR 1 (89/90)		
			EXPEND. BASE	REQUIRED NEW FUNDS	TOTAL
GENERAL FUND					
Personal Services Positions	2	2	2	0	2
Cost	\$53,681	\$56,365	\$59,183	\$0	\$59,183
Other Expense Con't	\$13,807	\$13,807	\$14,497	\$0	\$14,497
Nonrecurring Equipment	\$0	\$0	\$0	\$0	\$0
	\$8,770	\$0	\$0	\$0	\$0
SUBTOTAL	\$76,258	\$70,172	\$73,681	\$0	\$73,681
TUITION FUND					
Personal Services Positions	0	0	0	0	0
Cost	\$0	\$0	\$0	\$0	\$0
Other Expense Con't	\$14,717	\$14,717	\$15,453	\$0	\$15,453
Nonrecurring Equipment	\$0	\$0	\$0	\$0	\$0
	\$11,202	\$15,000	\$20,000	\$0	\$20,000
SUBTOTAL	\$25,919	\$29,717	\$35,453	\$0	\$35,453
EXTENSION FUND	\$0	\$0	\$0	\$0	\$0
AUXILIARY SERVICES	\$0	\$0	\$0	\$0	\$0
FEDERAL FUNDS	\$0	\$0	\$0	\$0	\$0
OTHER	\$0	\$0	\$0	\$0	\$0
TOTAL	<u>\$102,177</u>	<u>\$99,889</u>	<u>\$109,134</u>	<u>\$0</u>	<u>\$109,134</u>
TOTAL POSITIONS	2	2	2	0	2

NORWALK C.C.
ADMINISTRATIVE DP PLAN

INSTITUTIONAL EXPENDITURE SUMMARY

	87/88 CURRENT YEAR	88/89 BUDGETED YEAR	PLAN YEAR 1 (89/90)		
			EXPEND. BASE	REQUIRED NEW FUNDS	TOTAL
GENERAL FUND					
Personal Services					
Positions	2	2	2	0	2
Cost	\$63,673	\$66,857	\$70,199	\$0	\$70,199
Other Expense					
Con't	\$3,327	\$4,500	\$4,725	\$0	\$4,725
Nonrecurring	\$0	\$0	\$0	\$0	\$0
Equipment	\$16,644	\$0	\$0	\$0	\$0
SUBTOTAL	\$83,644	\$71,357	\$74,924	\$0	\$74,924
TUITION FUND					
Personal Services					
Positions	0	0	0	0	0
Cost	\$0	\$0	\$0	\$0	\$0
Other Expense					
Con't	\$20,101	\$20,101	\$21,106	\$0	\$21,106
Nonrecurring	\$0	\$0	\$0	\$0	\$0
Equipment	\$0	\$0	\$0	\$0	\$0
SUBTOTAL	\$20,101	\$20,101	\$21,106	\$0	\$21,106
EXTENSION FUND	\$0	\$0	\$0	\$0	\$0
AUXILIARY SERVICES	\$2,168	\$0	\$0	\$0	\$0
FEDERAL FUNDS	\$0	\$0	\$0	\$0	\$0
OTHER	\$0	\$0	\$0	\$0	\$0
TOTAL	\$105,913	\$91,458	\$96,031	\$0	\$96,031
TOTAL POSITIONS	2	2	2	0	2

QUINEBAUG VALLEY C.C.
ADMINISTRATIVE DP PLAN

INSTITUTIONAL EXPENDITURE SUMMARY

	87/88 CURRENT YEAR	88/89 BUDGETED YEAR	PLAN YEAR 1 (89/90)		
			EXPEND. BASE	REQUIRED NEW FUNDS	TOTAL
<u>GENERAL FUND</u>					
Personal Services					
Positions	0	0	0	0	0
Cost	\$0	\$0	\$0	\$0	\$0
Other Expense					
Con't	\$2,858	\$4,500	\$4,725	\$0	\$4,725
Nonrecurring	\$0	\$0	\$0	\$0	\$0
Equipment	\$20,460	\$8,500	\$18,950	\$0	\$18,950
SUBTOTAL	\$23,318	\$11,000	\$23,675	\$0	\$23,675
<u>TUITION FUND</u>					
Personal Services					
Positions	0	0	0	0	0
Cost	\$0	\$0	\$0	\$0	\$0
Other Expense					
Con't	\$4,966	\$4,966	\$5,214	\$0	\$5,214
Nonrecurring	\$0	\$0	\$0	\$0	\$0
Equipment	\$0	\$0	\$0	\$0	\$0
SUBTOTAL	\$4,966	\$4,966	\$5,214	\$0	\$5,214
EXTENSION FUND	\$0	\$0	\$0	\$0	\$0
AUXILIARY SERVICES	\$0	\$0	\$0	\$0	\$0
FEDERAL FUNDS	\$0	\$0	\$0	\$0	\$0
OTHER	\$0	\$0	\$0	\$0	\$0
TOTAL	\$28,284	\$15,966	\$28,889	\$0	\$28,889
TOTAL POSITIONS	0	0	0	0	0